

ATF 130G-5

160 TON CAPACITY

**ALL
TERRAIN
CRANE**



Dimensions (ft, mm) / Dimensiones (ft, mm)

 445/95 R 25 (16.00 R 25)	 525/80 R 25 (20.50 R 25)
---	---

SAE

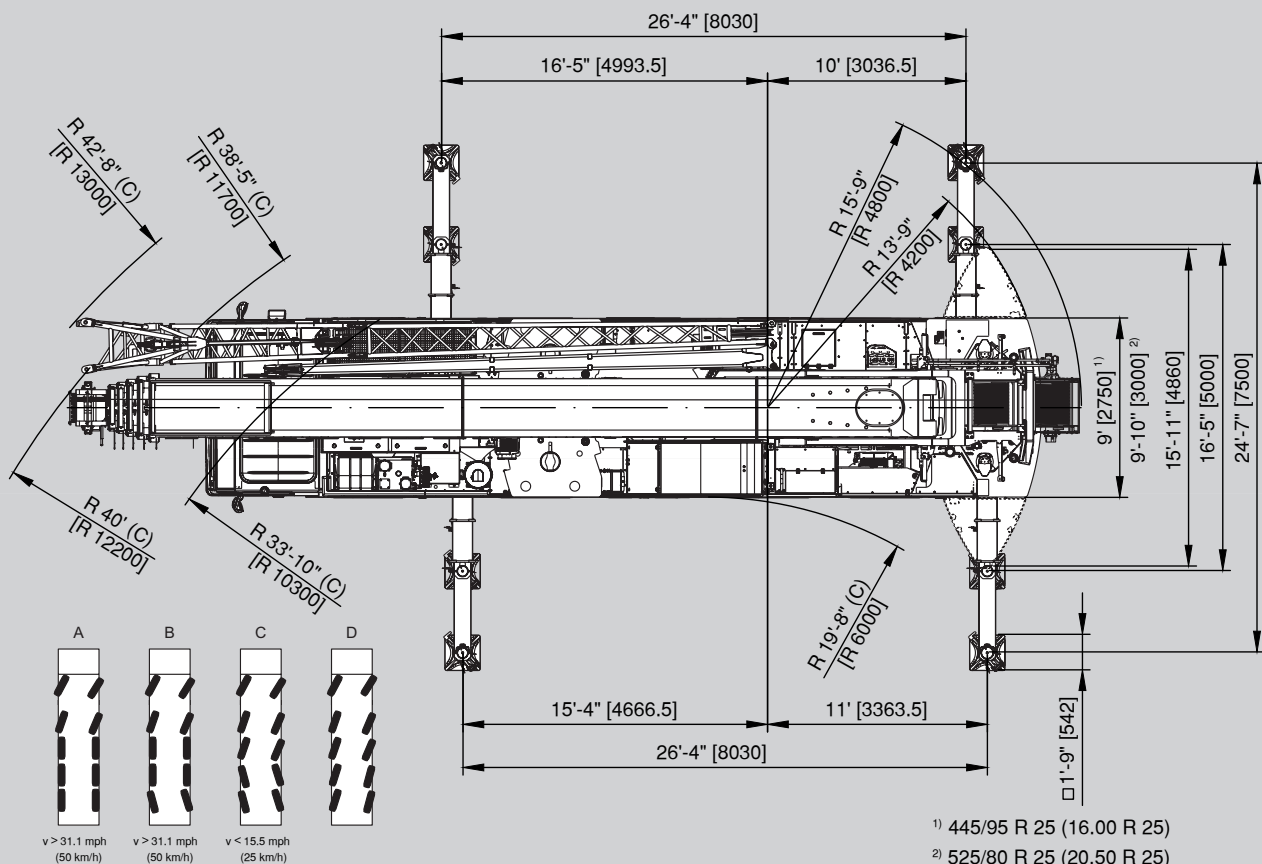
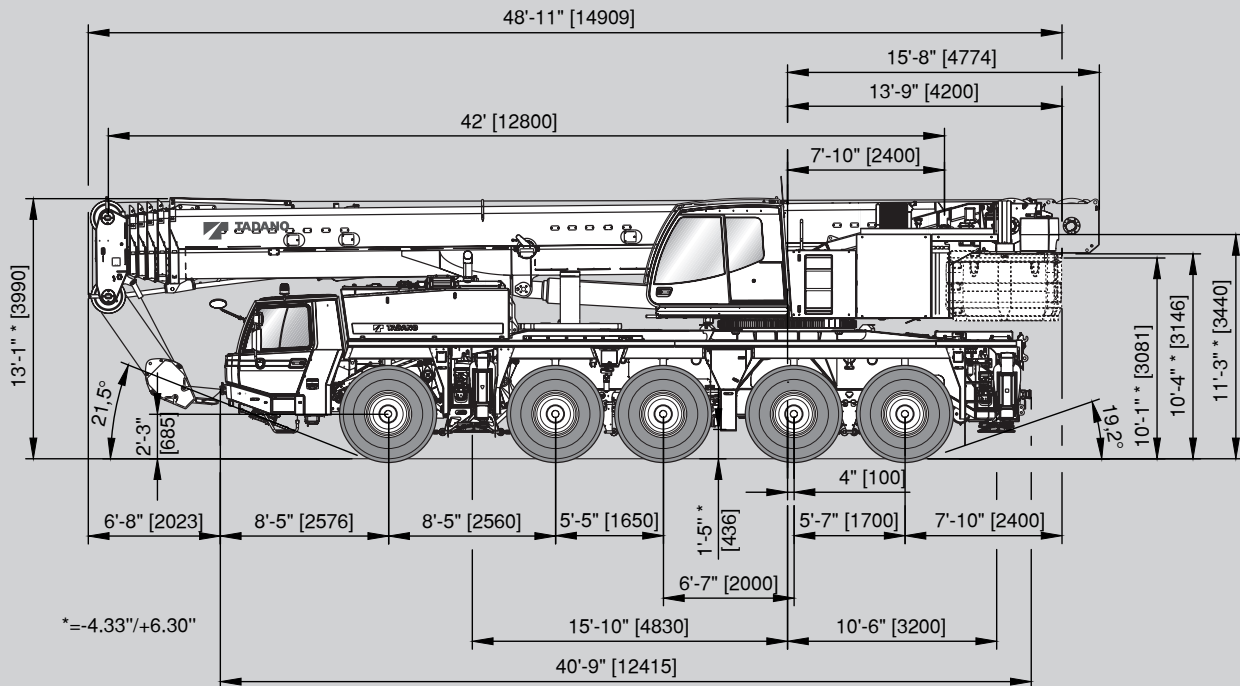

















Weights / Working speeds / Pesos / Velocidades de trabajo











 * Rams horn * Gancho doble	Lifting capacity Capacidad de elevación [lbs]	Sheaves Poleas	Part of line Ramales de cable	Weight Peso [lbs]
		251,250 (Type / Typo 137.7 ton)*	7	15
	184,250 (Type / Typo 88.2 ton)*	5	11	1,764
	117,250 (Type / Typo 69.4 ton)*	3	7	1,323
	117,250 (Type / Typo 69.4 ton)	3	7	1,323
	50,240 (Type / Typo 27.6 ton)	1	3	827
	16,750 (Type / Typo 11.0 ton)	-	1	661

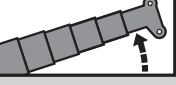

 445/95 (16.00) 525/80 (20.50) mph	 1	 2	 3	 4	 5	 6	 7	 8	 9	 10	 11	 12	 R1	 R2	 69%*
	1.9	1.9	2.5	3.7	4.3	5.6	7.5	9.3	12.4	15.5	19.9	25.5	1.9	2.5	52%

* Off road range / * Con transmisión todo terreno

 	Infinitely variable Infinitamente variable	Rope (diameter/length) Cable (diámetro/longitud)	Max. single line pull Trio máximo por ramal
	0 - 426.5 ft/min 0 - 130 m/min single line ramal simple	0.83"/ 820.2' 21 mm / 250 m	16,750 lbs 85 kN
	0 - 249.3 ft/min 0 - 76 m/min single line ramal simple	0.83"/ 820.2' 21 mm / 250 m	16,750 lbs 85 kN
	Max. permissible line pull may be affected by wire rope strength, which should not exceed 16,750 lbs for main winch and auxiliary winch La fuerza max del cabestrante es dependiente de la normativa en vigor, la cual no permite superar los 75 kN de fuerza.		
	0 - 1.6 rpm		
	-1.0° - +82.7°	approx. 42 s aproximadamente 42 s	
	42.0 ft - 196.8 ft 12.8 m - 60.0 m	approx. 380 s aproximadamente 380 s	

Lifting heights / Alturas de elevación

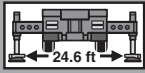
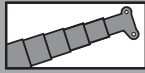

93,255 lbs

lbs x 1,000

SAE

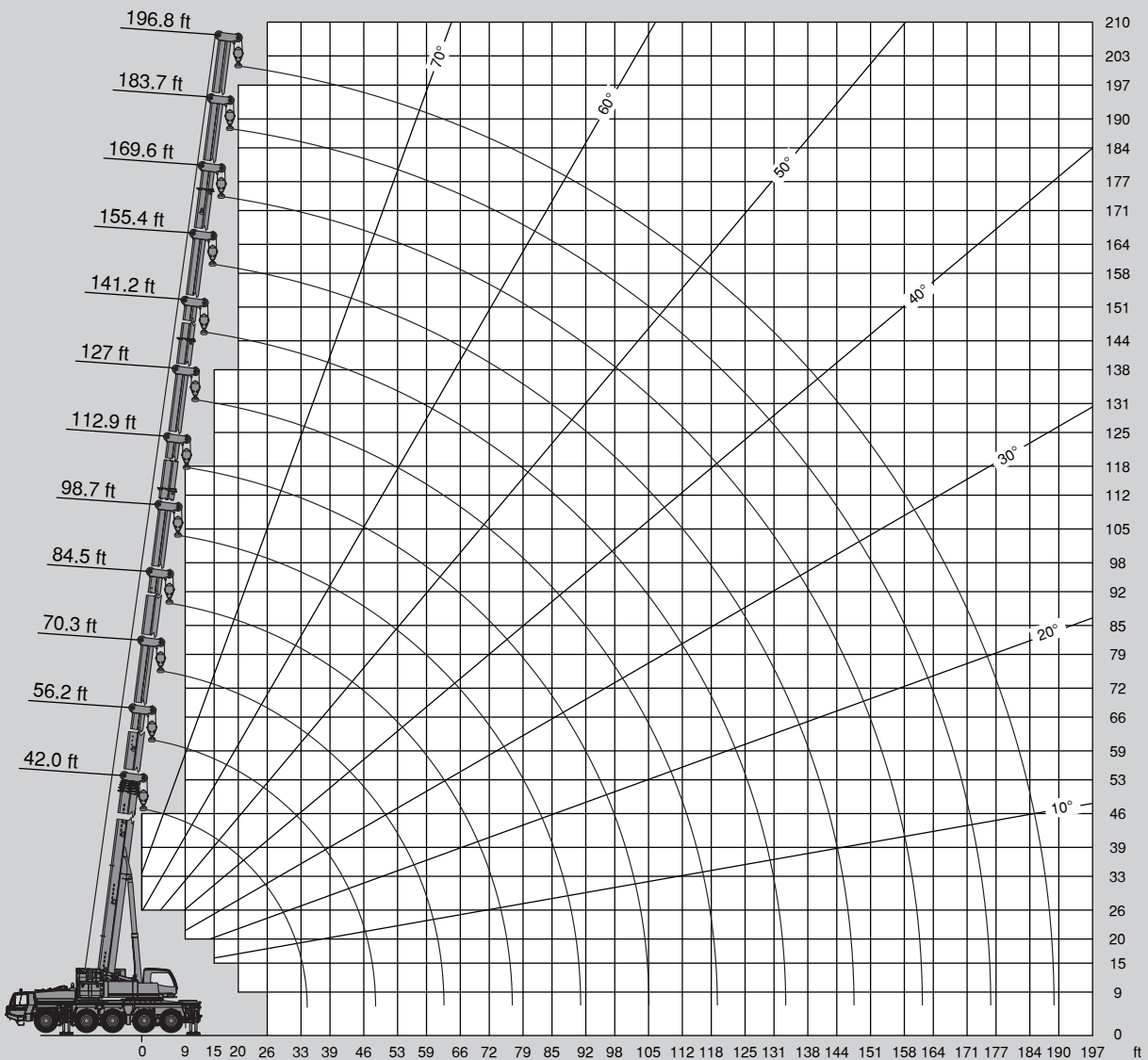





93,255 lbs



lbs x 1,000 SAE

 ft	42.0 ft*	42.0 ft	56.2 ft	70.3 ft	84.5 ft	98.7 ft	112.9 ft	127.0 ft	141.2 ft	155.4 ft	169.6 ft	183.7 ft	196.8 ft
8	320.0**												
9	286.6**												
10	245.2**	230.8**	198.4	198.4									
12	219.8	211.0	198.4	198.4	154.3								
13	201.5	194.2	194.0	193.1	154.3								
15	183.6	179.7	179.5	178.6	154.3	119.7							
16	167.1	167.1	166.9	166.0	154.3	113.1	97.0						
20	146.2	145.9	145.7	144.6	145.5	110.2	93.3	72.3					
23	129.6	128.1	128.5	126.8	128.1	108.7	84.7	72.3	59.7				
26	116.2	112.9	113.8	113.3	112.7	101.4	83.8	72.3	59.7	47.2			
30	105.2	100.1	101.0	101.0	99.9	95.0	78.9	66.8	59.7	47.2	36.6		
33	92.8	89.5	90.4	90.4	89.3	89.5	74.3	61.9	58.4	47.2	36.6	29.1	
36			81.6	81.6	80.5	82.0	70.1	57.8	54.5	47.2	36.6	29.1	23.4
39			74.1	74.1	73.9	74.5	66.4	54.0	50.9	47.0	36.6	29.1	23.4
46			62.2	61.9	63.3	62.4	60.0	47.6	45.0	42.3	36.6	29.1	23.4
53				50.5	51.8	50.9	52.7	42.5	40.1	38.4	34.8	29.1	23.4
59				43.7	43.4	45.4	44.1	38.4	36.8	34.6	32.0	28.2	23.4
66					38.4	38.8	37.5	34.8	33.5	31.1	29.8	26.5	23.1
72					35.3	34.4	33.1	31.1	30.6	28.0	26.9	24.7	21.4
79						30.6	29.3	28.4	28.0	25.4	24.3	22.9	19.8
85						27.3	26.0	26.2	25.4	23.1	22.0	21.6	18.1
92							23.4	24.0	22.9	21.2	20.3	19.8	16.5
98								22.3	21.6	20.5	19.2	18.5	15.2
105									19.4	18.5	17.4	16.8	13.9
112									17.6	16.8	16.3	15.9	12.8
118										15.7	15.0	14.6	11.9
125										14.6	13.7	13.4	11.0
131										13.7	12.6	12.6	10.1
138											11.5	11.7	9.5
144											10.4	10.8	8.8
151												9.9	8.4
158												9.0	7.7
164													7.1
171													6.4
177													5.7
184													5.3

* Over rear / * Sobre la parte trasera

** With additional lifting equipment / ** Con equipo adicional

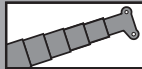
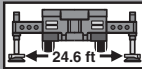
Lifting capacities / Capacidades de elevación



69,886 lbs

lbs x 1,000 SAE

 ft	42.0 ft*	42.0 ft	56.2 ft	70.3 ft	84.5 ft	98.7 ft	112.9 ft	127.0 ft	141.2 ft	155.4 ft	169.6 ft	183.7 ft	196.8 ft
9	286.6**												
10	238.8**	228.8**											
12	216.3	209.0	198.4	198.4	154.3								
13	196.7	192.5	192.2	191.4	154.3								
15	180.8	178.1	177.7	177.0	154.3	119.7							
16	165.6	165.1	164.9	163.8	154.3	113.1	97.0						
20	144.8	142.2	142.0	140.7	142.2	110.2	93.3	72.3					
23	128.5	122.8	123.5	123.0	122.6	108.7	84.7	72.3	59.7				
26	115.1	107.4	108.0	108.2	107.1	101.4	83.8	72.3	59.7	47.2			
30	103.4	95.0	95.7	95.9	94.6	95.0	78.9	66.8	59.7	47.2	36.6		
33	86.9	84.9	85.3	85.5	84.4	86.0	74.3	61.9	58.4	47.2	36.6	29.1	
36			75.2	75.2	76.7	75.8	70.1	57.8	54.5	47.2	36.6	29.1	23.4
39			65.3	65.5	67.0	65.9	66.4	54.0	50.9	47.0	36.6	29.1	23.4
46			54.7	51.1	52.5	54.9	53.6	47.6	45.0	42.3	36.6	29.1	23.4
53				43.9	45.2	44.8	43.4	42.1	40.1	38.4	34.8	29.1	23.4
59				39.7	37.9	37.5	36.2	35.1	36.2	34.6	32.0	28.2	23.4
66					33.3	31.7	31.7	32.0	30.6	30.0	29.8	26.5	23.1
72					29.3	28.2	27.8	27.3	26.2	26.0	26.2	24.7	21.4
79						25.1	25.4	23.8	23.4	23.4	23.4	22.9	19.8
85						22.5	22.7	21.6	21.6	21.2	20.7	20.9	18.1
92							20.5	19.2	19.8	19.0	19.0	18.7	16.5
98							18.3	17.2	18.1	16.8	17.4	16.5	15.2
105								15.4	16.3	15.0	15.7	14.6	13.9
112								13.9	14.6	13.7	13.9	13.0	12.6
118									12.8	12.6	12.3	11.5	11.2
125									11.9	11.5	11.0	10.1	9.9
131									11.2	10.6	9.9	8.8	8.8
138										9.7	8.8	7.7	7.7
144										8.8	7.7	6.8	6.6
151											7.1	6.0	5.7
158											6.4	5.1	5.1
164												4.4	4.4
171												3.7	3.7
177													3.1
184													2.4

* Over rear / * Sobre la parte trasera

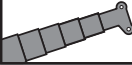
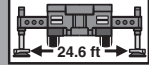
** With additional lifting equipment / ** Con equipo adicional

47,840 lbs



lbs x 1,000 SAE

 ft	42.0 ft*	42.0 ft	56.2 ft	70.3 ft	84.5 ft	98.7 ft	112.9 ft	127.0 ft	141.2 ft	155.4 ft	169.6 ft	183.7 ft	196.8 ft
9	264.6**												
10	235.9**	226.9**	198.4	198.4									
12	213.8	207.2	198.4	198.4	154.3								
13	195.1	190.7	190.5	189.6	154.3								
15	177.2	175.0	174.8	173.7	154.3	119.7							
16	164.0	160.7	160.5	159.2	154.3	113.1	97.0						
20	143.5	135.8	136.7	134.9	135.6	110.2	93.3	72.3					
23	127.2	116.6	117.5	117.7	116.4	108.7	84.7	72.3	59.7				
26	104.7	101.6	102.3	102.5	100.8	97.9	83.8	72.3	59.7	47.2			
30	85.1	85.1	86.0	86.2	88.0	84.2	78.9	66.8	59.7	47.2	36.6		
33	71.0	71.0	71.9	72.1	73.6	72.5	72.5	61.9	58.4	47.2	36.6	29.1	
36			61.3	61.3	63.1	65.7	64.2	57.8	54.5	47.2	36.6	29.1	23.4
39			53.4	54.0	57.1	57.1	55.6	53.6	50.9	47.0	36.6	29.1	23.4
46			46.3	45.0	45.2	44.8	43.4	42.1	43.2	41.2	36.6	29.1	23.4
53				37.7	38.1	36.2	35.3	36.4	35.1	34.2	34.2	29.1	23.4
59				32.0	32.2	30.9	30.9	30.2	29.1	29.8	28.9	28.2	23.4
66					27.6	26.7	27.1	26.2	26.0	24.9	25.6	24.9	23.1
72					23.8	22.9	23.6	22.5	23.1	22.7	22.0	22.1	20.9
79						19.8	20.3	19.2	20.3	19.5	19.7	18.6	18.5
85						17.2	17.6	16.5	17.9	17.2	17.2	16.2	16.1
92							16.1	15.0	16.1	15.2	15.2	13.9	13.6
98							15.0	13.7	14.3	13.1	13.0	12.0	11.8
105								12.3	12.8	11.5	11.5	10.1	10.1
112								11.5	11.2	10.2	9.7	8.8	8.5
118									9.9	9.0	8.6	7.3	7.3
125									8.8	7.9	7.3	6.4	6.4
131									7.7	7.1	6.4	5.1	5.1
138										6.2	5.3	4.2	4.2
144										5.3	4.4	3.3	3.3
151											4.0	2.6	2.6
158											3.1		

* Over rear / * Sobre la parte trasera

** With additional lifting equipment / ** Con equipo adicional

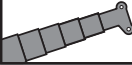
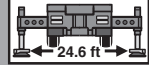
Lifting capacities / Capacidades de elevación

28,219 lbs

lbs x 1,000 SAE

 ft	42.0 ft*	42.0 ft	56.2 ft	70.3 ft	84.5 ft	98.7 ft	112.9 ft	127.0 ft	141.2 ft	155.4 ft	169.6 ft	183.7 ft	196.8 ft
9	264.6**												
10	235.7**	225.1**	198.4	198.4									
12	212.5	205.2	198.4	198.4	154.3								
13	192.0	187.0	186.7	185.6	154.3								
15	175.0	169.3	168.9	167.8	154.3	119.7							
16	162.7	153.9	154.8	152.6	153.9	113.1	97.0						
20	142.4	129.4	130.3	130.5	122.8	110.2	93.3	72.3					
23	109.8	109.8	111.1	108.0	102.7	95.7	84.7	72.3	59.7				
26	85.1	85.1	86.2	86.4	86.2	80.9	78.3	72.1	59.7	47.2			
30	68.6	68.6	69.7	69.9	71.6	71.9	66.6	61.5	58.9	47.2	36.6		
33	57.1	57.1	59.3	61.3	63.1	62.2	57.8	53.4	51.1	47.2	36.6	29.1	
36			53.1	53.6	53.8	53.4	50.5	48.3	46.7	43.9	36.6	29.1	23.4
39			46.8	46.3	46.7	46.1	44.8	44.8	41.4	40.8	36.6	29.1	23.4
46			36.8	37.7	37.7	35.7	36.8	35.9	34.6	33.3	31.5	29.1	23.4
53				30.7	30.7	29.5	30.4	28.4	29.4	29.3	27.8	25.8	23.4
59				25.1	25.7	24.3	24.9	23.6	25.1	24.3	23.4	22.0	21.2
66					21.7	20.3	22.0	20.9	21.6	20.1	20.2	18.8	18.3
72					18.7	17.4	19.2	18.2	18.5	17.2	16.9	16.0	15.9
79						15.4	16.8	15.9	16.0	14.9	14.3	13.5	13.4
85						13.9	14.3	13.9	13.7	12.8	12.1	11.1	11.1
92								12.1	11.9	11.7	11.0	10.1	9.3
98								10.6	10.1	9.9	9.3	8.6	7.3
105									8.8	8.6	7.7	7.1	5.7
112									7.5	7.3	6.6	5.7	4.6
118										6.4	5.4	4.6	3.7
125										5.3	4.4	3.7	2.6
131										4.4	3.7	2.9	
138											2.9	2.2	
144											2.2		

* Over rear / * Sobre la parte trasera

** With additional lifting equipment / ** Con equipo adicional





20,723 lbs



lbs x 1,000 **SAE**

 ft	42.0 ft*	42.0 ft	56.2 ft	70.3 ft	84.5 ft	98.7 ft	112.9 ft	127.0 ft	141.2 ft	155.4 ft	169.6 ft	183.7 ft	196.8 ft
9	264.6**												
10	235.7**	224.4**	198.4	198.4									
12	212.5	203.7	198.4	198.4	154.3								
13	191.8	184.3	184.1	182.8	154.3								
15	174.6	166.4	166.2	164.9	154.3	119.7							
16	162.3	151.2	152.1	149.7	146.4	113.1	97.0						
20	138.2	126.8	127.6	124.3	112.9	107.6	93.3	72.3					
23	100.3	100.3	101.6	99.2	95.0	87.3	83.8	72.3	59.7				
26	77.6	77.6	78.7	78.9	78.0	76.7	70.5	64.8	59.7	47.2			
30	62.4	62.4	65.0	65.9	69.0	65.0	60.0	55.1	52.7	47.2	36.6		
33	51.6	51.6	57.1	57.3	57.5	56.0	51.8	51.1	47.4	44.3	36.6	29.1	
36			48.9	50.1	50.6	48.5	45.4	45.2	41.7	41.0	36.6	29.1	23.4
39			42.3	44.2	44.6	42.8	43.0	39.9	37.7	36.6	34.2	29.1	23.4
46			32.8	34.4	34.8	33.7	34.2	32.2	31.7	31.5	29.8	27.6	23.4
53				27.1	27.9	26.9	27.6	26.5	27.8	26.0	24.5	22.7	22.0
59				22.0	23.2	21.6	23.4	22.9	23.3	22.2	20.9	19.4	18.7
66					19.6	18.7	19.7	19.8	19.2	18.4	17.6	16.4	16.3
72					16.5	16.3	17.0	16.8	16.2	15.5	14.7	13.6	13.7
79						14.1	14.3	14.1	13.9	13.0	12.3	11.2	11.2
85						11.9	12.1	11.7	11.7	11.0	10.1	9.0	9.0
92							10.1	9.9	9.7	9.0	8.2	7.3	7.3
98								8.8	8.2	7.5	6.8	5.5	5.5
105									7.1	6.8	6.2	5.3	4.4
112									5.7	5.7	4.9	4.4	3.1
118										4.9	4.0	3.1	2.2
125										4.0	3.1	2.4	
131										3.1	2.2		

* Over rear / * Sobre la parte trasera

** With additional lifting equipment / ** Con equipo adicional

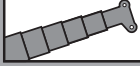
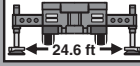
Lifting capacities / Capacidades de elevación

13,889 lbs

lbs x 1,000 **SAE**

 ft	42.0 ft*	42.0 ft	56.2 ft	70.3 ft	84.5 ft	98.7 ft	112.9 ft	127.0 ft	141.2 ft	155.4 ft	169.6 ft	183.7 ft	196.8 ft
9	264.6**												
10	235.7**	224.0**	198.4	198.4									
12	211.9	202.4	198.4	198.4	154.3								
13	191.1	181.7	181.2	180.1	154.3								
15	174.2	163.8	164.2	162.3	154.3	119.7							
16	161.8	148.6	149.5	149.0	134.9	113.1	97.0						
20	126.8	124.3	124.6	114.4	108.2	99.0	89.7	72.3					
23	91.7	91.7	93.0	90.2	86.2	84.0	76.7	69.9	59.7				
26	70.5	70.5	71.9	72.1	74.5	69.4	63.5	58.2	55.3	47.2			
30	56.7	56.7	60.8	62.8	62.6	58.6	53.8	53.1	48.9	45.6	36.6		
33	46.7	46.7	52.2	52.5	52.7	50.3	48.3	46.1	42.3	41.0	36.6	29.1	
36			44.8	45.9	44.8	43.9	43.7	40.3	39.5	36.8	34.2	29.1	23.4
39			38.4	39.9	39.7	37.9	38.6	35.7	35.3	34.6	31.5	29.1	23.4
46			28.9	30.6	31.7	30.0	30.9	29.8	29.8	28.0	26.2	24.3	23.4
53				24.3	25.1	24.0	25.6	25.1	24.3	22.9	21.6	19.6	19.2
59				19.4	20.5	20.5	20.9	20.7	20.3	19.4	18.5	16.8	15.9
66					17.0	17.0	17.2	17.2	17.0	16.1	15.4	14.1	13.7
72					14.1	14.1	14.3	14.3	14.3	13.0	12.6	11.5	11.2
79						11.9	12.1	11.9	11.9	10.8	10.1	9.0	9.0
85						9.9	10.1	9.9	9.7	9.0	8.2	7.1	7.1
92							8.6	8.2	7.9	7.3	6.6	5.3	5.3
98								7.3	6.8	6.6	5.7	5.1	4.0
105									5.5	5.3	4.6	4.0	2.9
112									4.6	4.4	3.7	2.9	
118										3.3	2.6		
125										2.6			

* Over rear / * Sobre la parte trasera

** With additional lifting equipment / ** Con equipo adicional





8,598 lbs

lbs x 1,000 **SAE**

 ft	42.0 ft*	42.0 ft	56.2 ft	70.3 ft	84.5 ft	98.7 ft	112.9 ft	127.0 ft	141.2 ft	155.4 ft	169.6 ft	183.7 ft	196.8 ft
9	259.0**												
10	232.6**	222.7**	198.4	198.4									
12	208.3	200.2	198.4	198.4	154.3								
13	187.2	179.0	178.8	177.7	154.3								
15	170.0	161.4	162.3	159.8	145.9	119.7							
16	153.7	146.2	147.3	140.2	124.8	112.0	97.0						
20	116.8	116.8	115.5	105.8	99.9	93.5	83.8	72.3					
23	84.2	84.2	85.8	81.8	82.2	76.6	69.7	63.3	59.5				
26	66.1	66.1	67.2	71.2	67.7	63.1	57.5	56.4	50.9	47.2			
30	54.9	54.9	58.6	58.0	56.9	53.1	51.4	48.1	44.1	41.0	36.6		
33	45.4	45.0	49.2	50.0	48.5	45.4	45.0	41.7	40.8	37.5	34.8	29.1	
36			41.0	43.2	42.3	39.5	39.2	36.4	37.3	34.6	31.5	29.1	23.4
39			34.6	36.6	36.6	34.8	34.6	32.8	33.3	31.1	29.1	26.9	23.4
46			25.4	27.1	28.7	27.1	29.1	27.8	26.7	24.9	23.4	21.4	20.7
53				21.2	22.5	22.5	23.4	22.7	22.3	20.3	19.6	17.9	17.2
59				16.8	18.3	18.3	18.7	18.5	18.1	17.1	16.5	14.8	14.3
66					14.8	15.0	15.4	15.0	14.8	13.9	13.4	12.1	11.9
72					12.1	12.3	12.6	12.3	12.1	11.3	10.6	9.5	9.5
79						9.9	10.4	10.1	9.9	9.1	8.6	7.3	7.3
85						8.2	8.6	8.2	7.9	7.3	6.6	5.3	5.3
92							7.1	6.6	6.6	5.7	5.1	4.0	4.0
98							5.7	5.3	5.3	4.4	3.7	2.6	2.6
105								4.4	4.2	3.3	2.6		
112								3.3	3.1	2.4			

* Over rear / * Sobre la parte trasera

** With additional lifting equipment / ** Con equipo adicional

Lifting heights / Alturas de elevación

		 HYDRO	 24.6 ft	 360°	93,255 lbs	lbs x 1,000	SAE
---	---	---	---	--	------------	-------------	-----

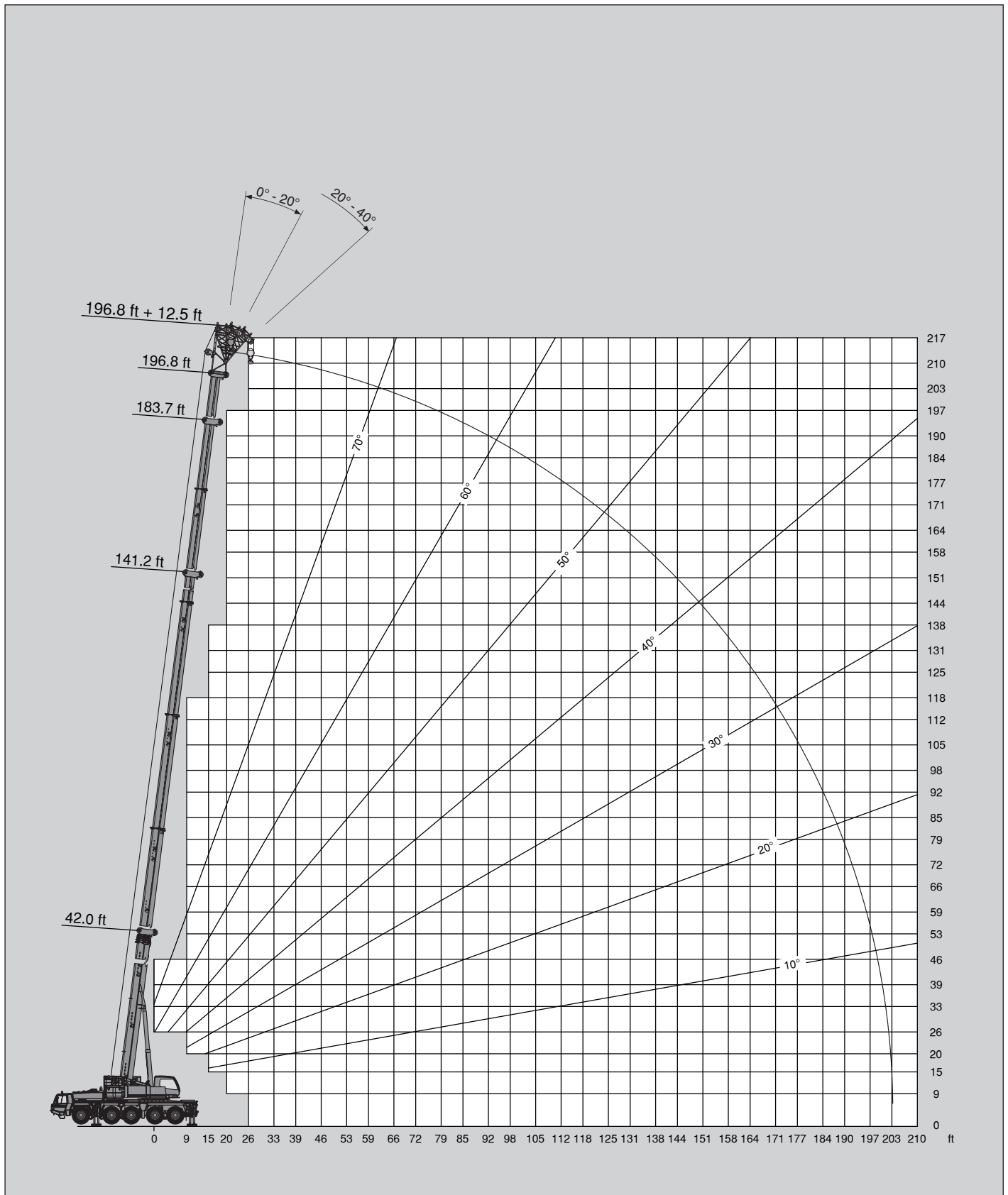

		 HYDRO	 24.6 ft	 360°	93,255 lbs	lbs x 1,000	SAE
---	---	---	---	--	------------	-------------	-----

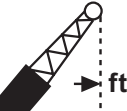
 ft	42.0 ft + 12.5 ft			141.2 ft + 12.5 ft			183.7 ft + 12.5 ft			196.8 ft + 12.5 ft		
	0°	20°	40°	0°	20°	40°	0°	20°	40°	0°	20°	40°
10	88.2	72.1										
12	88.2	69.0	55.6									
13	88.2	66.1	54.0									
15	85.8	63.7	52.5									
16	81.1	61.3	51.1									
20	73.4	57.3	48.9									
23	67.0	53.8	47.0									
26	61.7	50.9	45.2									
30	57.3	48.5	43.9	36.6	33.1	31.1						
33	53.6	46.3	43.0	34.8	31.7	30.0						
36	50.5	44.5	42.3	33.5	30.6	28.9						
39	47.6	43.2		32.2	29.5	28.0	19.8	19.8				
46	44.1			29.8	27.6	26.2	19.8	19.4	18.7	17.2	17.2	17.2
53				27.8	26.0	24.9	19.2	18.3	17.9	17.2	16.8	16.3
59				26.2	24.5	23.6	18.1	17.4	17.0	16.5	15.9	15.4
66				24.9	23.4	22.7	17.0	16.5	16.1	15.7	15.2	14.8
72				23.6	22.3	21.6	16.1	15.7	15.4	14.8	14.3	14.1
79				22.0	21.4	20.9	15.2	15.0	14.8	14.1	13.7	13.4
85				20.5	20.3	20.3	14.3	14.1	13.9	13.4	13.0	13.0
92				19.2	19.0	19.2	13.7	13.4	13.2	12.8	12.6	12.3
98				17.9	17.9	17.9	13.0	12.8	12.6	12.1	11.9	11.7
105				16.1	16.3	16.5	12.3	12.1	11.9	11.5	11.2	11.2
112				14.3	14.6	14.8	11.7	11.5	11.5	11.0	10.8	10.8
118				12.6	12.8		11.2	11.0	11.0	10.4	10.4	10.1
125				11.0	11.2		10.8	10.6	10.6	9.9	9.9	9.9
131				9.7	9.9		10.4	10.1	10.1	9.7	9.5	9.5
144				7.5			8.8	8.8	9	8.2	8.4	8.4
158							6.8	7.1		6.8	7.1	
171							5.3	5.3		5.3	5.3	
184							4.0			4.0	4.0	
197										2.9		

Lifting capacities / Capacidades de elevación







69,886 lbs

lbs x 1,000 SAE

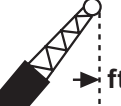
 ft	42.0 ft + 12.5 ft			141.2 ft + 12.5 ft			183.7 ft + 12.5 ft			196.8 ft + 12.5 ft		
	0°	20°	40°	0°	20°	40°	0°	20°	40°	0°	20°	40°
10	88.2	72.1										
12	88.2	69.0	55.6									
13	88.2	66.1	54.0									
15	85.8	63.7	52.5									
16	81.1	61.3	51.1									
20	73.4	57.3	48.9									
23	67.0	53.8	47.0									
26	61.7	50.9	45.2									
30	57.3	48.5	43.9	36.6	33.1	31.1						
33	53.6	46.3	43.0	34.8	31.7	30.0						
36	50.5	44.5	42.3	33.5	30.6	28.9						
39	47.6	43.2		32.2	29.5	28.0	19.8	19.8				
46	44.1			29.8	27.6	26.2	19.8	19.4	18.7	17.2	17.2	17.2
53				27.8	26.0	24.9	19.2	18.3	17.9	17.2	16.8	16.3
59				26.2	24.5	23.6	18.1	17.4	17.0	16.5	15.9	15.4
66				24.9	23.4	22.7	17.0	16.5	16.1	15.7	15.2	14.8
72				23.6	22.3	21.6	16.1	15.7	15.4	14.8	14.3	14.1
79				21.4	21.4	20.9	15.2	15.0	14.8	14.1	13.7	13.4
85				18.5	19.0	19.2	14.3	14.1	13.9	13.4	13.0	13.0
92				15.9	16.1	16.5	13.7	13.4	13.2	12.8	12.6	12.3
98				13.4	13.9	14.1	13.0	12.8	12.6	12.1	11.9	11.7
105				11.7	11.9	12.1	12.3	12.1	11.9	11.5	11.2	11.2
112				9.9	10.1	10.4	11.5	11.5	11.5	11.0	10.8	10.8
118				8.4	8.6		9.9	10.1	10.4	9.9	10.1	10.1
125				7.3	7.3		8.6	8.8	9.0	8.6	8.8	9.0
131				6.2	6.2		7.5	7.7	7.7	7.5	7.7	7.7
144				4.2			5.5	5.7	5.7	5.5	5.7	5.7
158							4.0	4.0		4.0	4.0	
171							2.6	2.6		2.4	2.6	







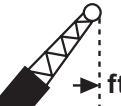

47,840 lbs

lbs x 1,000 SAE

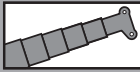
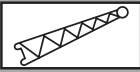
 ft	141.2 ft + 12.5 ft			183.7 ft + 12.5 ft			196.8 ft + 12.5 ft		
	0°	20°	40°	0°	20°	40°	0°	20°	40°
30	36.6	33.1	31.1						
33	34.8	31.7	30.0						
36	33.5	30.6	28.9						
39	32.2	29.5	28.0	19.8	19.8				
46	29.8	27.6	26.2	19.8	19.4	18.7	17.2	17.2	17.2
53	27.8	26.0	24.9	19.2	18.3	17.9	17.2	16.8	16.3
59	26.2	24.5	23.6	18.1	17.4	17.0	16.5	15.9	15.4
66	22.7	23.4	22.7	17.0	16.5	16.1	15.7	15.2	14.8
72	18.7	19.2	19.8	16.1	15.7	15.4	14.8	14.3	14.1
79	15.4	15.9	16.3	15.2	15.0	14.8	14.1	13.7	13.4
85	12.8	13.2	13.7	14.3	14.1	13.9	13.4	13.0	13.0
92	10.6	11.0	11.2	12.1	12.6	12.8	12.1	12.6	12.3
98	8.8	9.0	9.3	10.4	10.6	10.8	10.4	10.6	10.8
105	7.1	7.5	7.7	8.6	9.0	9.3	8.6	9.0	9.3
112	5.7	6.0	6.2	7.3	7.5	7.7	7.3	7.5	7.7
118	4.6	4.9		6.2	6.2	6.4	6.0	6.2	6.4
125	3.5	3.7		4.9	5.3	5.3	4.9	5.1	5.3
131	2.6	2.6		4.0	4.2	4.4	4.0	4.2	4.2
144				2.4	2.6	2.6	2.4	2.4	2.6

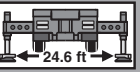
28,219 lbs

lbs x 1,000 **SAE**

 ft	141.2 ft + 12.5 ft			183.7 ft + 12.5 ft			196.8 ft + 12.5 ft		
	0°	20°	40°	0°	20°	40°	0°	20°	40°
30	36.6	33.1	31.1						
33	34.8	31.7	30.0						
36	33.5	30.6	28.9						
39	32.2	29.5	28.0	19.8	19.8				
46	29.8	27.6	26.2	19.8	19.4	18.7	17.2	17.2	17.2
53	24.9	25.6	24.9	19.2	18.3	17.9	17.2	16.8	16.3
59	20.3	20.9	21.6	18.1	17.4	17.0	16.5	15.9	15.4
66	16.1	16.5	17.2	17.0	16.5	16.1	15.7	15.2	14.8
72	12.8	13.2	13.9	14.3	15.0	15.2	14.1	14.3	14.1
79	10.1	10.6	11.0	11.7	12.1	12.6	11.7	12.1	12.6
85	7.9	8.4	8.8	9.5	9.9	10.1	9.5	9.9	10.1
92	6.2	6.4	6.8	7.7	8.2	8.4	7.7	7.9	8.4
98	4.6	4.9	5.3	6.2	6.4	6.6	6.2	6.4	6.6
105	3.3	3.5	3.7	4.9	5.1	5.3	4.9	5.1	5.3
112	2.2	2.4	2.6	3.7	4.0	4.2	3.5	4.0	4.0
118				2.6	2.9	3.1	2.6	2.9	3.1
125					2.0	2.2		2.0	2.2

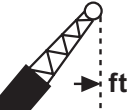





20,723 lbs

lbs x 1,000 **SAE**

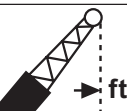
 ft	141.2 ft + 12.5 ft			183.7 ft + 12.5 ft			196.8 ft + 12.5 ft		
	0°	20°	40°	0°	20°	40°	0°	20°	40°
30	36.6	33.1	31.1						
33	34.8	31.7	30.0						
36	33.5	30.6	28.9						
39	32.2	29.5	28.0	19.8	19.8				
46	26.9	27.6	26.2	19.8	19.4	18.7	17.2	17.2	17.2
53	21.6	22.3	22.9	19.2	18.3	17.9	17.2	16.8	16.3
59	17.2	18.1	18.7	17.6	17.4	17.0	16.5	15.9	15.4
66	13.4	14.1	14.6	14.6	15.0	15.4	14.1	14.3	14.1
72	10.4	11.0	11.5	12.1	12.6	13.0	11.7	12.1	12.6
79	7.9	8.4	8.8	9.7	10.1	10.4	9.7	10.1	10.4
85	6.0	6.4	6.8	7.7	7.9	8.4	7.5	7.9	8.4
92	4.4	4.6	5.1	6.0	6.4	6.6	6.0	6.4	6.6
98	3.1	3.3	3.5	4.6	4.9	5.1	4.4	4.9	5.1
105		2.0	2.4	3.3	3.5	3.7	3.3	3.5	3.7
112				2.2	2.6	2.6	2.2	2.4	2.6

Lifting heights / Alturas de elevación

		HYDRO	24.6 ft	360°	93,255 lbs	lbs x 1,000	SAE
--	--	-------	---------	------	------------	-------------	-----

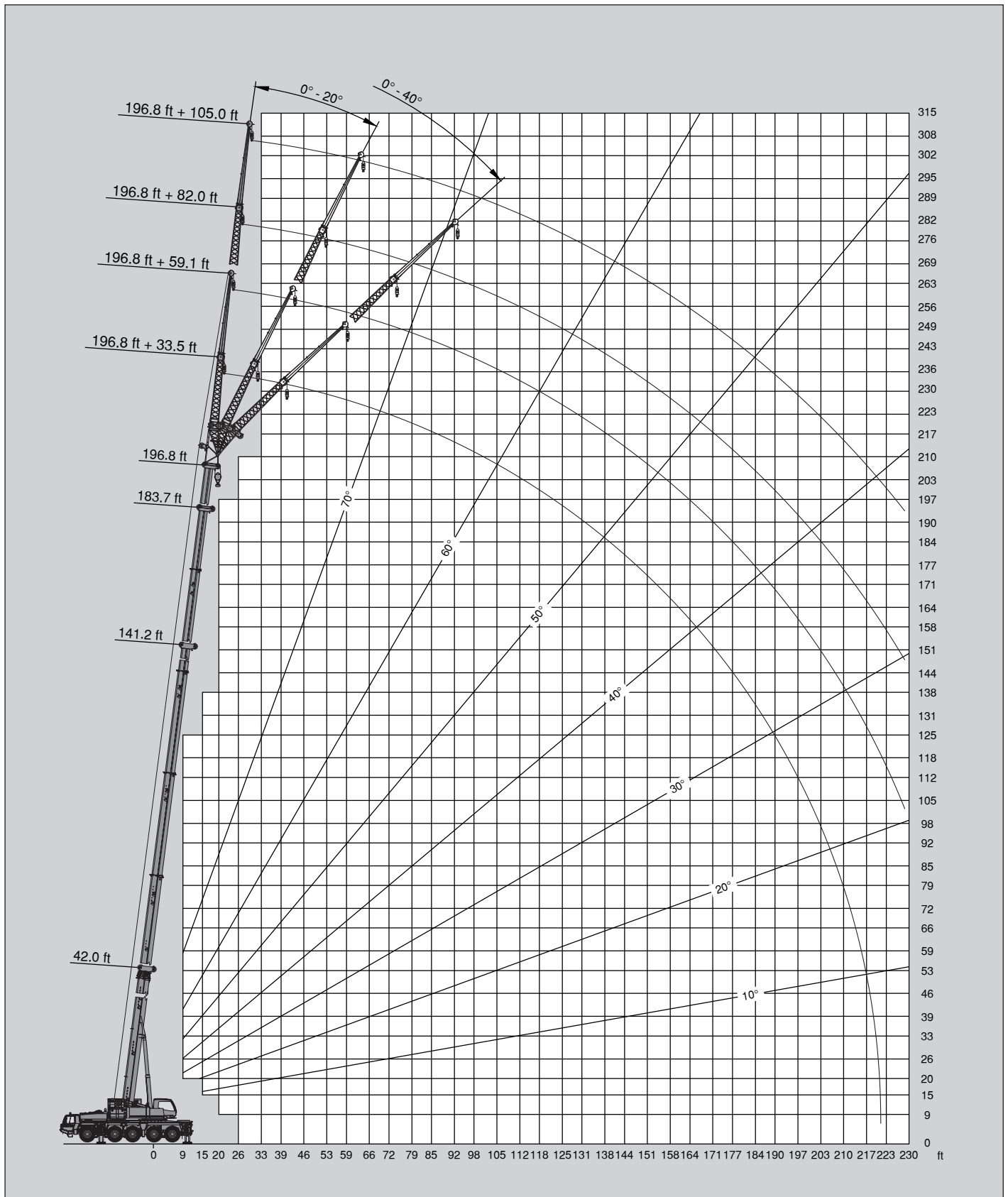







93,255 lbs

lbs x 1,000 SAE

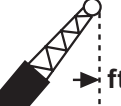
 ft	141.2 ft + 33.5 ft			141.2 ft + 59.1 ft			141.2 ft + 82.0 ft			141.2 ft + 105.0 ft		
	0°	20°	40°	0°	20°	40°	0°	20°	40°	0°	20°	40°
26	23.4											
30	23.4											
33	23.4			12.1								
36	23.4			12.1			8.4					
39	23.4	22.3		12.1			8.4			6.0		
46	23.4	20.7	18.1	12.1			8.4			6.0		
53	23.1	19.6	17.0	12.1	9.0		8.4			6.0		
59	21.8	18.3	16.3	11.9	8.6		8.4			6.0		
66	20.5	17.4	15.7	11.5	8.2	6.6	8.4	7.9		6.0		
72	19.4	16.5	15.0	10.8	7.9	6.4	8.4	7.7		6.0		
79	18.3	15.9	14.3	10.4	7.5	6.2	8.4	7.5		6.0	5.7	
85	17.4	15.2	13.9	9.9	7.3	6.0	8.4	7.3	6.0	6.0	5.5	
92	16.5	14.6	13.4	9.5	7.1	6.0	8.2	7.1	5.7	6.0	5.3	
98	15.9	14.1	13.0	9.0	6.8	5.7	8.2	6.8	5.5	6.0	5.1	
105	15.2	13.7	12.6	8.6	6.6	5.7	7.9	6.6	5.3	6.0	5.1	4.0
112	14.8	13.2	12.3	8.4	6.4	5.5	7.7	6.4	5.3	6.0	4.9	3.7
118	13.4	12.8	12.1	7.9	6.2	5.5	7.5	6.2	5.1	5.7	4.6	3.5
125	11.9	12.6	11.7	7.7	6.0	5.3	7.3	6.0	4.9	5.5	4.6	3.5
131	10.6	11.2	11.7	7.5	6.0	5.3	7.1	5.7	4.9	5.3	4.4	3.3
144	8.4	8.8		7.1	5.7	5.3	6.4	5.5	4.6	4.9	4.0	3.3
158	6.6	6.8		6.6	5.5	5.3	5.7	5.1	4.4	4.2	3.7	3.1
171				6.2	5.5		5.1	4.9	4.4	3.7	3.5	2.9
184				4.9			4.6	4.6		3.3	3.3	2.9
197							4.0	4.4		2.9	3.1	2.9
210							3.1			2.6	2.9	
223										2.4	2.9	







93,255 lbs

lbs x 1,000 SAE

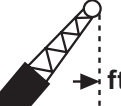
 ft	183.7 ft + 33.5 ft			183.7 ft + 59.1 ft			183.7 ft + 82.0 ft			183.7 ft + 105.0 ft		
	0°	20°	40°	0°	20°	40°	0°	20°	40°	0°	20°	40°
39	14.1											
46	14.1			8.6			6.4					
53	14.1	14.1		8.6			6.4			4.6		
59	14.1	13.4	12.6	8.6			6.4			4.6		
66	14.1	12.8	11.9	8.6	7.7		6.4			4.6		
72	13.7	12.1	11.5	8.6	7.5		6.4			4.6		
79	13.0	11.7	11.0	8.6	7.3	6.0	6.4	6.4		4.6		
85	12.3	11.2	10.6	8.6	7.1	5.7	6.4	6.4		4.6		
92	11.9	10.8	10.1	8.6	6.6	5.5	6.4	6.4		4.6		
98	11.5	10.4	9.9	8.6	6.6	5.5	6.4	6.2	5.5	4.6	4.4	
105	10.8	10.1	9.5	8.4	6.4	5.3	6.4	6.0	5.3	4.6	4.4	
112	10.4	9.7	9.3	8.2	6.2	5.3	6.4	5.7	5.3	4.6	4.2	
118	10.1	9.5	9.0	7.9	6.0	5.1	6.2	5.5	5.1	4.6	4.2	
125	9.7	9.0	8.8	7.5	5.7	5.1	6.0	5.3	4.9	4.6	4.0	3.5
131	9.3	8.8	8.6	7.3	5.7	5.1	5.7	5.1	4.9	4.6	4.0	3.5
144	8.4	8.4	8.2	6.8	5.5	4.9	5.5	4.9	4.4	4.4	3.7	3.3
158	7.3	7.7	7.7	6.6	5.3	4.6	5.1	4.4	4.2	4.0	3.5	3.1
171	5.7	6.2		6.2	5.1	4.6	4.9	4.2	4.0	3.7	3.3	3.1
184	4.4	4.9		5.1	5.1	4.6	4.4	4.0	3.7	3.5	3.1	2.9
197	3.3	3.5		4.0	4.4		4.2	3.7	3.5	3.3	2.9	2.6
210				2.9	3.3		3.1	3.7	3.5	3.1	2.6	2.4
223				2.0	2.2		2.2	2.9		2.6	2.6	2.4
236								2.0		2.4	2.4	2.2

Lifting capacities / Capacidades de elevación







93,255 lbs

lbs x 1,000

SAE

ft	196.8 ft + 33.5 ft			196.8 ft + 59.1 ft			196.8 ft + 82.0 ft			196.8 ft + 105.0 ft		
	0°	20°	40°	0°	20°	40°	0°	20°	40°	0°	20°	40°
39	12.6											
46	12.6			7.9								
53	12.6	12.6		7.9			6.0					
59	12.6	12.3		7.9			6.0			4.4		
66	12.6	11.9	11.0	7.9			6.0			4.4		
72	12.6	11.2	10.6	7.9	7.3		6.0			4.4		
79	11.9	10.8	10.1	7.9	7.1		6.0			4.4		
85	11.5	10.4	9.9	7.9	6.8	5.7	6.0	6.0		4.4		
92	11.0	9.9	9.5	7.9	6.6	5.5	6.0	6.0		4.4		
98	10.4	9.7	9.3	7.9	6.4	5.3	6.0	5.7		4.4	4.2	
105	9.9	9.3	8.8	7.9	6.2	5.3	6.0	5.5	5.1	4.4	4.2	
112	9.7	9.0	8.6	7.5	6.0	5.1	6.0	5.3	5.1	4.4	4.0	
118	9.3	8.8	8.4	7.3	6.0	5.1	5.7	5.1	4.9	4.4	4.0	
125	8.8	8.4	8.2	7.1	5.7	4.9	5.5	5.1	4.6	4.4	4.0	3.5
131	8.6	8.2	7.9	6.8	5.7	4.9	5.3	4.9	4.4	4.2	3.7	3.5
144	7.9	7.5	7.3	6.4	5.3	4.6	5.1	4.4	4.2	4.0	3.5	3.3
158	6.8	6.6	6.6	5.7	5.1	4.6	4.6	4.2	4.0	3.7	3.3	3.1
171	5.5	6.0	6.0	5.1	4.9	4.6	4.2	3.7	3.7	3.5	3.1	2.9
184	4.2	4.9		4.6	4.4	4.4	3.7	3.5	3.3	3.1	2.9	2.6
197	3.1	3.5		3.7	4.0	4.0	3.3	3.1	3.1	2.9	2.6	2.4
210	2.2	2.4		2.6	3.3		2.9	2.9	2.9	2.4	2.4	2.2
223					2.2		2.0	2.6	2.6	2.2	2.0	2.2
236												2.0











69,886 lbs

lbs x 1,000

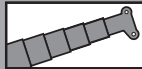
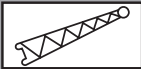
SAE

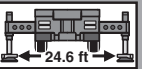
ft	141.2 ft + 33.5 ft			141.2 ft + 59.1 ft			141.2 ft + 82.0 ft			141.2 ft + 105.0 ft		
	0°	20°	40°	0°	20°	40°	0°	20°	40°	0°	20°	40°
26	23.4											
30	23.4											
33	23.4			12.1								
36	23.4			12.1			8.4					
39	23.4	22.3		12.1			8.4			6.0		
46	23.4	20.7	18.1	12.1			8.4			6.0		
53	23.1	19.6	17.0	12.1	9.0		8.4			6.0		
59	21.8	18.3	16.3	11.9	8.6		8.4			6.0		
66	20.5	17.4	15.7	11.5	8.2	6.6	8.4	7.9		6.0		
72	19.4	16.5	15.0	10.8	7.9	6.4	8.4	7.7		6.0		
79	18.3	15.9	14.3	10.4	7.5	6.2	8.4	7.5		6.0	5.7	
85	17.4	15.2	13.9	9.9	7.3	6.0	8.4	7.3	6.0	6.0	5.5	
92	16.5	14.6	13.4	9.5	7.1	6.0	8.2	7.1	5.7	6.0	5.3	
98	14.6	14.1	13.0	9.0	6.8	5.7	8.2	6.8	5.5	6.0	5.1	
105	12.6	13.7	12.6	8.6	6.6	5.7	7.9	6.6	5.3	6.0	5.1	4.0
112	10.8	11.7	12.3	8.4	6.4	5.5	7.7	6.4	5.3	6.0	4.9	3.7
118	9.5	10.1	10.8	7.9	6.2	5.5	7.5	6.2	5.1	5.7	4.6	3.5
125	8.2	8.8	9.3	7.7	6.0	5.3	7.3	6.0	4.9	5.5	4.6	3.5
131	7.1	7.5	7.9	7.5	6.0	5.3	7.1	5.7	4.9	5.3	4.4	3.3
144	5.1	5.5		6.2	5.7	5.3	6.4	5.5	4.6	4.9	4.0	3.3
158	3.5	3.7		4.6	5.5	5.3	5.3	5.1	4.4	4.2	3.7	3.1
171				3.3	4.0		3.7	4.9	4.4	3.7	3.5	2.9
184				2.2			2.6	3.5		3.1	3.3	2.9
197								2.2		2.2	3.1	2.9
210											2.0	

69,886 lbs

lbs x 1,000 SAE

 ft	183.7 ft + 33.5 ft			183.7 ft + 59.1 ft			183.7 ft + 82.0 ft			183.7 ft + 105.0 ft		
	0°	20°	40°	0°	20°	40°	0°	20°	40°	0°	20°	40°
39	14.1											
46	14.1			8.6			6.4					
53	14.1	14.1		8.6			6.4			4.6		
59	14.1	13.4	12.6	8.6			6.4			4.6		
66	14.1	12.8	11.9	8.6	7.7		6.4			4.6		
72	13.7	12.1	11.5	8.6	7.5		6.4			4.6		
79	13.0	11.7	11.0	8.6	7.3	6.0	6.4	6.4		4.6		
85	12.3	11.2	10.6	8.6	7.1	5.7	6.4	6.4		4.6		
92	11.9	10.8	10.1	8.6	6.6	5.5	6.4	6.4		4.6		
98	11.5	10.4	9.9	8.6	6.6	5.5	6.4	6.2	5.5	4.6	4.4	
105	10.8	10.1	9.5	8.4	6.4	5.3	6.4	6.0	5.3	4.6	4.4	
112	10.4	9.7	9.3	8.2	6.2	5.3	6.4	5.7	5.3	4.6	4.2	
118	10.1	9.5	9.0	7.9	6.0	5.1	6.2	5.5	5.1	4.6	4.2	
125	8.8	9.0	8.8	7.5	5.7	5.1	6.0	5.3	4.9	4.6	4.0	3.5
131	7.7	8.8	8.6	7.3	5.7	5.1	5.7	5.1	4.9	4.6	4.0	3.5
144	5.7	6.6	7.1	6.6	5.5	4.9	5.5	4.9	4.4	4.4	3.7	3.3
158	4.2	4.9	5.3	5.1	5.3	4.6	5.1	4.4	4.2	4.0	3.5	3.1
171	2.9	3.5		3.7	4.4	4.6	4.0	4.2	4.0	3.7	3.3	3.1
184		2.2		2.6	3.3	3.5	2.9	3.7	3.7	3.1	3.1	2.9
197					2.2			2.6	3.3	2.2	2.9	2.6
210									2.2		2.2	2.4
223												2.0

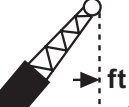





69,886 lbs

lbs x 1,000 SAE

 ft	196.8 ft + 33.5 ft			196.8 ft + 59.1 ft			196.8 ft + 82.0 ft			196.8 ft + 105.0 ft		
	0°	20°	40°	0°	20°	40°	0°	20°	40°	0°	20°	40°
39	12.6											
46	12.6			7.9								
53	12.6	12.6		7.9			6.0					
59	12.6	12.3		7.9			6.0			4.4		
66	12.6	11.9	11.0	7.9			6.0			4.4		
72	12.6	11.2	10.6	7.9	7.3		6.0			4.4		
79	11.9	10.8	10.1	7.9	7.1		6.0			4.4		
85	11.5	10.4	9.9	7.9	6.8	5.7	6.0	6.0		4.4		
92	11.0	9.9	9.5	7.9	6.6	5.5	6.0	6.0		4.4		
98	10.4	9.7	9.3	7.9	6.4	5.3	6.0	5.7		4.4	4.2	
105	9.9	9.3	8.8	7.9	6.2	5.3	6.0	5.5	5.1	4.4	4.2	
112	9.7	9.0	8.6	7.5	6.0	5.1	6.0	5.3	5.1	4.4	4.0	
118	9.3	8.8	8.4	7.3	6.0	5.1	5.7	5.1	4.9	4.4	4.0	
125	8.8	8.4	8.2	7.1	5.7	4.9	5.5	5.1	4.6	4.4	4.0	3.5
131	7.7	8.2	7.9	6.8	5.7	4.9	5.3	4.9	4.4	4.2	3.7	3.5
144	5.7	6.6	7.1	6.4	5.3	4.6	5.1	4.4	4.2	4.0	3.5	3.3
158	4.0	4.9	5.3	4.9	5.1	4.6	4.6	4.2	4.0	3.7	3.3	3.1
171	2.6	3.5	3.7	3.5	4.4	4.6	3.7	3.7	3.7	3.5	3.1	2.9
184		2.2		2.4	3.1	3.5	2.6	3.5	3.3	2.9	2.9	2.6
197					2.0	2.4		2.6	3.1		2.6	2.4
210									2.0		2.2	2.2
223												2.0

Lifting capacities / Capacidades de elevación



47,840 lbs lbs x 1,000 **SAE**

ft	141.2 ft + 33.5 ft			141.2 ft + 59.1 ft			141.2 ft + 82.0 ft			141.2 ft + 105.0 ft		
	0°	20°	40°	0°	20°	40°	0°	20°	40°	0°	20°	40°
26	23.4											
30	23.4											
33	23.4			12.1								
36	23.4			12.1			8.4					
39	23.4	22.3		12.1			8.4			6.0		
46	23.4	20.7	18.1	12.1			8.4			6.0		
53	23.1	19.6	17.0	12.1	9.0		8.4			6.0		
59	21.8	18.3	16.3	11.9	8.6		8.4			6.0		
66	20.5	17.4	15.7	11.5	8.2	6.6	8.4	7.9		6.0		
72	19.4	16.5	15.0	10.8	7.9	6.4	8.4	7.7		6.0		
79	16.5	15.9	14.3	10.4	7.5	6.2	8.4	7.5		6.0	5.7	
85	13.9	15.2	13.9	9.9	7.3	6.0	8.4	7.3	6.0	6.0	5.5	
92	11.7	12.8	13.4	9.5	7.1	6.0	8.2	7.1	5.7	6.0	5.3	
98	9.7	10.8	11.7	9.0	6.8	5.7	8.2	6.8	5.5	6.0	5.1	
105	8.2	9.0	9.9	8.6	6.6	5.7	7.9	6.6	5.3	6.0	5.1	4.0
112	6.8	7.7	8.2	8.2	6.4	5.5	7.7	6.4	5.3	6.0	4.9	3.7
118	5.5	6.4	6.8	6.8	6.2	5.5	7.5	6.2	5.1	5.7	4.6	3.5
125	4.4	5.1	5.5	5.7	6.0	5.3	6.4	6.0	4.9	5.5	4.6	3.5
131	3.5	4.2	4.4	4.9	6.0	5.3	5.3	5.7	4.9	5.3	4.4	3.3
144	2.0	2.4		3.1	4.2	4.9	3.7	5.1	4.6	4.2	4.0	3.3
158					2.6	3.1	2.4	3.5	4.4	2.9	3.7	3.1
171								2.2	2.9		3.1	2.9
184											2.0	2.9



47,840 lbs lbs x 1,000 **SAE**

ft	183.7 ft + 33.5 ft			183.7 ft + 59.1 ft			183.7 ft + 82.0 ft			183.7 ft + 105.0 ft		
	0°	20°	40°	0°	20°	40°	0°	20°	40°	0°	20°	40°
39	14.1											
46	14.1			8.6			6.4					
53	14.1	14.1		8.6			6.4			4.6		
59	14.1	13.4	12.6	8.6			6.4			4.6		
66	14.1	12.8	11.9	8.6	7.7		6.4			4.6		
72	13.7	12.1	11.5	8.6	7.5		6.4			4.6		
79	13.0	11.7	11.0	8.6	7.3	6.0	6.4	6.4		4.6		
85	12.3	11.2	10.6	8.6	7.1	5.7	6.4	6.4		4.6		
92	11.9	10.8	10.1	8.6	6.6	5.5	6.4	6.4		4.6		
98	10.6	10.4	9.9	8.6	6.6	5.5	6.4	6.2	5.5	4.6	4.4	
105	9.0	10.1	9.5	8.4	6.4	5.3	6.4	6.0	5.3	4.6	4.4	
112	7.5	8.8	9.3	8.2	6.2	5.3	6.4	5.7	5.3	4.6	4.2	
118	6.4	7.5	8.2	7.3	6.0	5.1	6.2	5.5	5.1	4.6	4.2	
125	5.3	6.4	7.1	6.2	5.7	5.1	6.0	5.3	4.9	4.6	4.0	3.5
131	4.4	5.3	5.7	5.3	5.7	5.1	5.5	5.1	4.9	4.6	4.0	3.5
144	2.6	3.5	4.0	3.5	4.6	4.9	4.0	4.9	4.4	4.2	3.7	3.3
158		2.2	2.4	2.2	3.1	4.0	2.4	4.0	4.2	2.9	3.5	3.1
171					2.0	2.4		2.6	3.5		3.3	3.1
184									2.2		2.0	2.9
197												2.0







47,840 lbs

lbs x 1,000 SAE

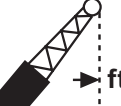
 ft	196.8 ft + 33.5 ft			196.8 ft + 59.1 ft			196.8 ft + 82.0 ft			196.8 ft + 105.0 ft		
	0°	20°	40°	0°	20°	40°	0°	20°	40°	0°	20°	40°
39	12.6											
46	12.6			7.9								
53	12.6	12.6		7.9			6.0					
59	12.6	12.3		7.9			6.0			4.4		
66	12.6	11.9	11.0	7.9			6.0			4.4		
72	12.6	11.2	10.6	7.9	7.3		6.0			4.4		
79	11.9	10.8	10.1	7.9	7.1		6.0			4.4		
85	11.5	10.4	9.9	7.9	6.8	5.7	6.0	6.0		4.4		
92	11.0	9.9	9.5	7.9	6.6	5.5	6.0	6.0		4.4		
98	10.4	9.7	9.3	7.9	6.4	5.3	6.0	5.7		4.4	4.2	
105	8.8	9.3	8.8	7.9	6.2	5.3	6.0	5.5	5.1	4.4	4.2	
112	7.5	8.8	8.6	7.5	6.0	5.1	6.0	5.3	5.1	4.4	4.0	
118	6.2	7.5	8.2	7.1	6.0	5.1	5.7	5.1	4.9	4.4	4.0	
125	5.1	6.4	6.8	6.0	5.7	4.9	5.5	5.1	4.6	4.4	4.0	3.5
131	4.2	5.3	5.7	5.1	5.7	4.9	5.3	4.9	4.4	4.2	3.7	3.5
144	2.6	3.5	4.0	3.3	4.6	4.6	3.7	4.4	4.2	4.0	3.5	3.3
158		2.0	2.4	2.0	3.1	3.7	2.2	3.7	4.0	2.6	3.3	3.1
171						2.4		2.4	3.3		3.1	2.9
184									2.0		2.0	2.6
197												2.0







28,219 lbs

lbs x 1,000 SAE

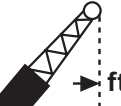
 ft	141.2 ft + 33.5 ft			141.2 ft + 59.1 ft			141.2 ft + 82.0 ft			141.2 ft + 105.0 ft		
	0°	20°	40°	0°	20°	40°	0°	20°	40°	0°	20°	40°
26	23.4											
30	23.4											
33	23.4			12.1								
36	23.4			12.1			8.4					
39	23.4	22.3		12.1			8.4			6.0		
46	23.4	20.7	18.1	12.1			8.4			6.0		
53	23.1	19.6	17.0	12.1	9.0		8.4			6.0		
59	20.5	18.3	16.3	11.9	8.6		8.4			6.0		
66	17.0	17.4	15.7	11.5	8.2	6.6	8.4	7.9		6.0		
72	13.7	15.4	15.0	10.8	7.9	6.4	8.4	7.7		6.0		
79	11.0	12.6	13.9	10.4	7.5	6.2	8.4	7.5		6.0	5.7	
85	8.8	10.4	11.5	9.9	7.3	6.0	8.4	7.3	6.0	6.0	5.5	
92	7.1	8.4	9.3	8.6	7.1	6.0	8.2	7.1	5.7	6.0	5.3	
98	5.5	6.6	7.5	7.1	6.8	5.7	7.7	6.8	5.5	6.0	5.1	
105	4.2	5.3	6.0	5.7	6.6	5.7	6.4	6.6	5.3	6.0	5.1	4.0
112	3.1	4.0	4.6	4.4	6.2	5.5	5.1	6.4	5.3	5.7	4.9	3.7
118	2.2	2.9	3.5	3.5	5.1	5.5	4.0	6.2	5.1	4.6	4.6	3.5
125		2.0	2.4	2.6	4.0	5.1	3.1	5.1	4.9	3.7	4.6	3.5
131					3.1	4.0	2.4	4.0	4.9	2.9	4.4	3.3
144						2.2		2.4	3.5		3.5	3.3
158									2.0		2.0	3.1
171												2.0

Lifting capacities / Capacidades de elevación







28,219 lbs

lbs x 1,000 **SAE**

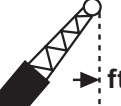
 ft	183.7 ft + 33.5 ft			183.7 ft + 59.1 ft			183.7 ft + 82.0 ft			183.7 ft + 105.0 ft		
	0°	20°	40°	0°	20°	40°	0°	20°	40°	0°	20°	40°
39	14.1											
46	14.1			8.6			6.4					
53	14.1	14.1		8.6			6.4			4.6		
59	14.1	13.4	12.6	8.6			6.4			4.6		
66	14.1	12.8	11.9	8.6	7.7		6.4			4.6		
72	13.7	12.1	11.5	8.6	7.5		6.4			4.6		
79	11.9	11.7	11.0	8.6	7.3	6.0	6.4	6.4		4.6		
85	9.7	11.2	10.6	8.6	7.1	5.7	6.4	6.4		4.6		
92	7.9	9.7	10.1	8.6	6.6	5.5	6.4	6.4		4.6		
98	6.4	7.9	8.8	7.5	6.6	5.5	6.4	6.2	5.5	4.6	4.4	
105	5.1	6.6	7.3	6.2	6.4	5.3	6.4	6.0	5.3	4.6	4.4	
112	4.0	5.3	6.0	4.9	6.2	5.3	5.3	5.7	5.3	4.6	4.2	
118	2.9	4.2	4.9	4.0	5.5	5.1	4.2	5.5	5.1	4.6	4.2	
125	2.0	3.1	3.7	3.1	4.4	5.1	3.3	5.3	4.9	3.7	4.0	3.5
131		2.4	2.9	2.2	3.5	4.6	2.6	4.4	4.9	2.9	4.0	3.5
144					2.0	2.9		2.6	4.0		3.5	3.3
158									2.4			3.1









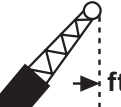

28,219 lbs

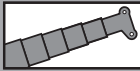
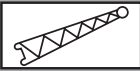
lbs x 1,000 **SAE**

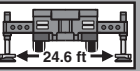
 ft	196.8 ft + 33.5 ft			196.8 ft + 59.1 ft			196.8 ft + 82.0 ft			196.8 ft + 105.0 ft		
	0°	20°	40°	0°	20°	40°	0°	20°	40°	0°	20°	40°
39	12.6											
46	12.6			7.9								
53	12.6	12.6		7.9			6.0					
59	12.6	12.3		7.9			6.0			4.4		
66	12.6	11.9	11.0	7.9			6.0			4.4		
72	12.6	11.2	10.6	7.9	7.3		6.0			4.4		
79	11.5	10.8	10.1	7.9	7.1		6.0			4.4		
85	9.7	10.4	9.9	7.9	6.8	5.7	6.0	6.0		4.4		
92	7.9	9.5	9.5	7.9	6.6	5.5	6.0	6.0		4.4		
98	6.2	7.9	8.8	7.3	6.4	5.3	6.0	5.7		4.4	4.2	
105	5.1	6.4	7.3	6.0	6.2	5.3	6.0	5.5	5.1	4.4	4.2	
112	3.7	5.3	6.0	4.9	6.0	5.1	5.1	5.3	5.1	4.4	4.0	
118	2.9	4.0	4.9	3.7	5.3	5.1	4.0	5.1	4.9	4.4	4.0	
125	2.0	3.1	3.7	2.9	4.4	4.9	3.1	5.1	4.6	3.5	4.0	3.5
131		2.2	2.9		3.5	4.4		4.2	4.4		3.7	3.5
144						2.9		2.6	4.0		3.3	3.3
158												3.1

20,723 lbs

lbs x 1,000 SAE

 ft	141.2 ft + 33.5 ft			141.2 ft + 59.1 ft			141.2 ft + 82.0 ft			141.2 ft + 105.0 ft		
	0°	20°	40°	0°	20°	40°	0°	20°	40°	0°	20°	40°
26	23.4											
30	23.4											
33	23.4			12.1								
36	23.4			12.1			8.4					
39	23.4	22.3		12.1			8.4			6.0		
46	23.4	20.7	18.1	12.1			8.4			6.0		
53	21.4	19.6	17.0	12.1	9.0		8.4			6.0		
59	17.6	18.3	16.3	11.9	8.6		8.4			6.0		
66	14.3	16.3	15.7	11.5	8.2	6.6	8.4	7.9		6.0		
72	11.5	13.2	14.6	10.8	7.9	6.4	8.4	7.7		6.0		
79	9.0	10.6	11.9	10.4	7.5	6.2	8.4	7.5		6.0	5.7	
85	7.1	8.4	9.5	8.6	7.3	6.0	8.4	7.3	6.0	6.0	5.5	
92	5.3	6.6	7.5	6.8	7.1	6.0	7.5	7.1	5.7	6.0	5.3	
98	4.0	5.1	6.0	5.5	6.8	5.7	6.0	6.8	5.5	6.0	5.1	
105	2.6	3.7	4.4	4.2	6.0	5.7	4.9	6.6	5.3	5.3	5.1	4.0
112		2.6	3.3	3.1	4.9	5.5	3.7	6.0	5.3	4.4	4.9	3.7
118			2.2	2.2	3.7	4.9	2.9	4.9	5.1	3.3	4.6	3.5
125					2.6	3.7	2.0	3.7	4.9	2.4	4.6	3.5
131						2.6		2.9	4.4		4.0	3.3
144									2.4		2.4	3.3
158												2.4

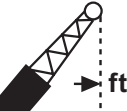





20,723 lbs

lbs x 1,000 SAE

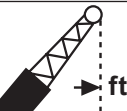
 ft	183.7 ft + 33.5 ft			183.7 ft + 59.1 ft			183.7 ft + 82.0 ft			183.7 ft + 105.0 ft		
	0°	20°	40°	0°	20°	40°	0°	20°	40°	0°	20°	40°
39	14.1											
46	14.1			8.6			6.4					
53	14.1	14.1		8.6			6.4			4.6		
59	14.1	13.4	12.6	8.6			6.4			4.6		
66	14.1	12.8	11.9	8.6	7.7		6.4			4.6		
72	11.9	12.1	11.5	8.6	7.5		6.4			4.6		
79	9.9	11.5	11.0	8.6	7.3	6.0	6.4	6.4		4.6		
85	7.9	9.7	10.6	8.6	7.1	5.7	6.4	6.4		4.6		
92	6.2	7.9	8.8	7.3	6.6	5.5	6.4	6.4		4.6		
98	4.9	6.4	7.3	6.0	6.6	5.5	6.2	6.2	5.5	4.6	4.4	
105	3.5	5.1	5.7	4.6	6.4	5.3	5.1	6.0	5.3	4.6	4.4	
112	2.6	4.0	4.6	3.5	5.3	5.3	4.0	5.7	5.3	4.2	4.2	
118		2.9	3.5	2.6	4.2	5.1	2.9	5.1	5.1	3.3	4.2	
125		2.0	2.6		3.3	4.4		4.0	4.9		4.0	
131					2.4	3.5		3.1	4.6		4.0	
144									2.9			

Lifting capacities / Capacidades de elevación







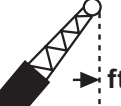

20,723 lbs

lbs x 1,000 SAE

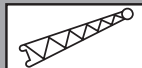
 ft	196.8 ft + 33.5 ft			196.8 ft + 59.1 ft			196.8 ft + 82.0 ft			196.8 ft + 105.0 ft		
	0°	20°	40°	0°	20°	40°	0°	20°	40°	0°	20°	40°
39	12.6											
46	12.6			7.9								
53	12.6	12.6		7.9			6.0					
59	12.6	12.3		7.9			6.0			4.4		
66	12.6	11.9	11.0	7.9			6.0			4.4		
72	11.5	11.2	10.6	7.9	7.3		6.0			4.4		
79	9.5	10.8	10.1	7.9	7.1		6.0			4.4		
85	7.7	9.3	9.9	7.9	6.8	5.7	6.0	6.0		4.4		
92	6.2	7.7	8.8	6.8	6.6	5.5	6.0	6.0		4.4		
98	4.6	6.2	7.3	5.7	6.4	5.3	5.7	5.7		4.4	4.2	
105	3.5	4.9	5.7	4.4	6.2	5.3	4.6	5.5	5.1	4.4	4.2	
112		3.7	4.4	3.3	5.1	5.1	3.7	5.3	5.1	4.0	4.0	
118		2.9	3.5		4.0	5.1		4.9	4.9		4.0	
125			2.4		3.1	4.4		4.0	4.6		4.0	
131						3.3		3.1	4.4		3.7	
144									2.9			



13,889 lbs

lbs x 1,000 SAE

 ft	196.8 ft + 33.5 ft			196.8 ft + 59.1 ft			196.8 ft + 82.0 ft			196.8 ft + 105.0 ft		
	0°	20°	40°	0°	20°	40°	0°	20°	40°	0°	20°	40°
39	12.6											
46	12.6			7.9								
53	12.6	12.6		7.9			6.0					
59	12.6	12.3		7.9			6.0			4.4		
66	11.5	11.9	11.0	7.9			6.0			4.4		
72	9.7	11.2	10.6	7.9	7.3		6.0			4.4		
79	7.9	9.9	10.1	7.9	7.1		6.0			4.4		
85	6.4	8.2	9.0	6.8	6.8	5.7	6.0	6.0		4.4		
92	4.9	6.8	7.5	5.5	6.6	5.5	5.3	6.0		4.4		
98	3.7	5.3	6.2	4.6	6.4	5.3	4.6	5.7		4.4		
105		4.0	4.9		5.3	5.3		5.5	5.1			
112			3.7		4.4	5.1		4.9	5.1			
118						4.4		4.2	4.9			
125						3.3			4.6			
131									3.7			

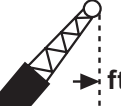
		 HYDRO	 24.6 ft	 360°	8,598 lbs	lbs x 1,000	SAE
---	---	--	--	---	------------------	-------------	------------

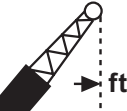
 ft	196.8 ft + 33.5 ft			196.8 ft + 59.1 ft			196.8 ft + 82.0 ft			196.8 ft + 105.0 ft		
	0°	20°	40°	0°	20°	40°	0°	20°	40°	0°	20°	40°
39	12.6											
46	12.6			7.9								
53	12.6	12.6		7.9			6.0					
59	11.9	12.3		7.9			6.0					
66	9.5	11.5	11.0	7.9			6.0					
72	7.5	9.3	10.6	7.9	7.3		6.0					
79	6.0	7.5	8.8	6.4	7.1		6.0					
85	4.4	6.0	7.1	5.1	6.8	5.7	5.1					
92		4.6	5.7		6.0	5.5						
98		3.5	4.4		4.6	5.3						
105					3.7	5.3						
112						4.2						

Axle weight distribution chart / Distribución de pesos por ejes

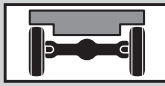
	Axle Eje	1	2	3	4	5	Total weight Peso total
	Tires 525/80 R 25 (20.50 R 25) [lbs]		29,060	28,995	22,783	23,308	23,053

Boom to front	Total [lbs]	Axle 1 [lbs]	Axle 2 [lbs]	Axle 3 [lbs]	Axle 4 [lbs]	Axle 5 [lbs]
Base machine with Equipment for USA, 16.00 R 25 tires, 10 x 8 drive, no counterweight, no fuel	110,581	24,441	24,419	20,271	20,853	20,597
* Fuel in carrier	915	-191	-189	439	428	428
* Fuel in superstructure	474	-65	-64	204	199	199
* Driver in carrier	176	134	132	-30	-30	-30
11.0 ton [10.0 t]** hook ball in storage	662	61	60	183	179	179
27.6 ton ([25.0 t])* (1 sheave) hook block at boom head	662	643	637	-209	-204	-204
69.4 ton [63.0 t]* (3 sheaves) hook block at boom head	1,323	1286	1273	-419	-409	-409
* 33.5 ft / 59.1 ft boom extensions	4462	2598	2572	-240	-234	-234
33.5 ft / 59.1 ft hydraulically boom extensions	5180	3175	3144	-386	-377	-377
* Auxiliary winch with cable	3,241	-1,398	-1,384	2,041	1,991	1,991
* Auxiliary boom point sheave (single top)	152	160	158	-56	-55	-55
* 2 nd oil cooler	99	-12	-12	41	40	40
* Air conditioning carrier	108	81	80	-18	-18	-18
* 20.50 R 25 tires in lieu of 16.00 R 25 tires	1,103	221	221	221	221	221
Towing attachment	176	-70	-70	107	105	105
Eddy-current brake	946	157	156	215	209	209
* Tool box at rear	154	-63	-63	95	93	93

* Basic configuration, marked items are included

Counterweight at the upper:						
Counterweight 1: 3,307 lbs [1.5 t]** behind winch	3,261	-1,390	-1,376	2,043	1,992	1,992
Counterweight 2+3: 2 x 2,645 lbs [1.2 t]**	5,433	-1,892	-1,873	3,117	3,041	3,041
Counterweight 4: 6,834 lbs [3.1 t]**	6,921	-2,410	-2,386	3,971	3,874	3,874
Counterweight 6: 2 x 11,685 lbs [5.3t]**	23,594	-8,217	-8,134	13,536	13,204	13,204

Counterweight on the carrier:						
Counterweight 9: 5,291 lbs [2.4 t]** base plate	5,171	1,784	1,766	549	536	536
Counterweight 8: 7,496 lbs [3.4 t]**	7,497	2,586	2,560	797	777	777
Counterweight 7: 19,621 lbs [8.9 t]**	19,267	6,646	6,580	2,047	1,997	1,997
Counterweight 5: 22,046 lbs [10.0 t]**	21,962	7,581	7,505	2,330	2,273	2,273

** Metric

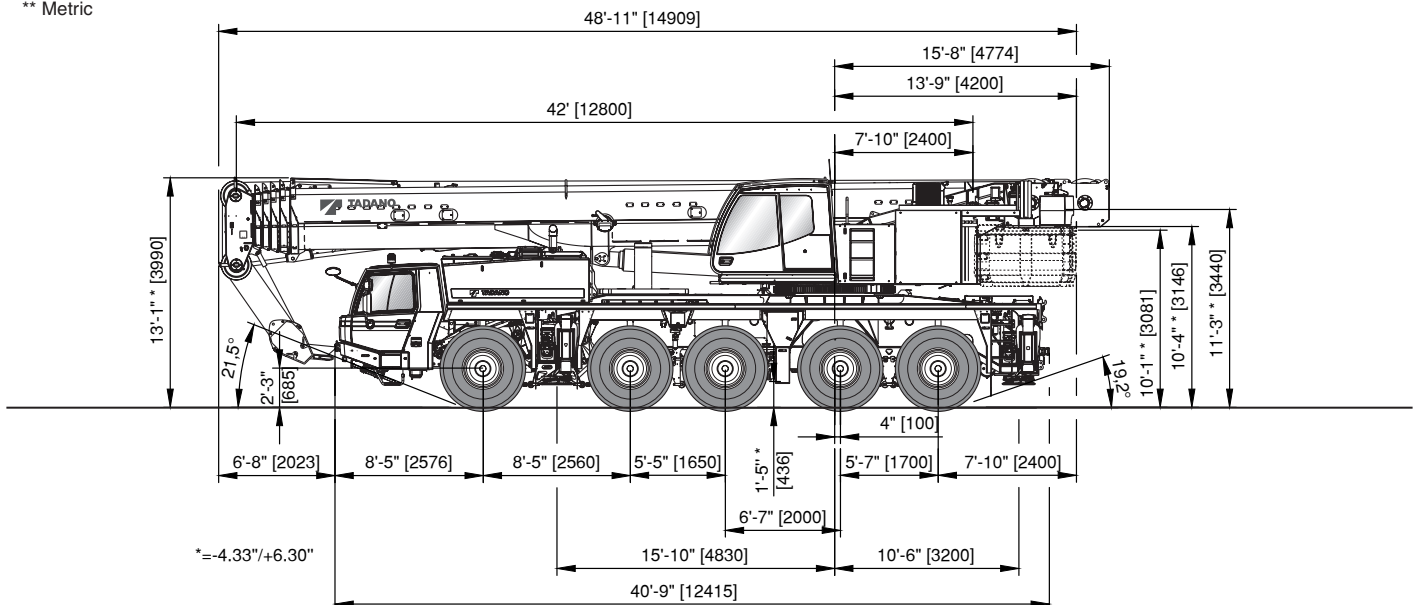

Axle weight distribution chart / Distribución de pesos por ejes

Axle Eje	1	2	3	4	5	Dolly	Total weight Peso total
Tires 525/80 R 25 (20.50 R 25) [lbs]	20,376	20,398	19,190	19,563	19,307	22,950	121,784*

Boom in dolly, 34 ft behind boom pivot point	Total [lbs]	Axle 1 [lbs]	Axle 2 [lbs]	Axle 3 [lbs]	Axle 4 [lbs]	Axle 5 [lbs]	Dolly [lbs]
Base machine with Equipment for USA, 16.00 R 25 tires, 10 x 8 drive, no counterweight, no fuel	110,345	18,506	18,544	17,804	18,206	17,950	19,334
* Fuel in carrier	915	-191	-189	439	428	428	0
* Fuel in superstructure	474	63	62	118	115	115	0
* Driver in carrier	198	150	149	-34	-33	-33	0
11.0 ton [10.0 t]** hook ball at boom head	-153	-38	-38	-26	-26	-26	814
69.4 ton [63.0 t]** (3 sheaves) hook block	-305	-76	-75	-52	-51	-51	1,628
* 33.5 ft / 59.1 ft boom extensions	1,029	256	253	176	172	172	3,433
33.5 ft / 59.1 ft hydraulically boom extensions	1,013	252	249	173	169	169	4,330
* Auxiliary winch with cable	3,241	1,387	1,373	163	159	159	0
* Auxiliary boom point sheave (single top)	-31	-8	-8	-5	-5	-5	183
* 2 nd oil cooler	99	11	11	26	25	25	0
* Air conditioning carrier	108	81	80	-18	-18	-18	0
* 20.50 R 25 tires in lieu of 16.00 R 25 tires	1,103	221	221	221	221	221	0
Towing attachment	176	-70	-70	107	105	105	0
Eddy-current brake	946	157	156	215	209	209	0
* Tool box at rear	154	-63	-63	95	93	93	0

* Basic configuration, marked items are included

Counterweight at the upper:							
Counterweight 1: 3,307 lbs [1.5 t]** behind winch	3,261	1,379	1,365	175	171	171	0
Counterweight 2+3: 2 x 2,645 lbs [1.2 t]**	5,433	1,874	1,855	577	563	563	0
Counterweight 4: 6,834 lbs [3.1 t]**	6,921	2,388	2,364	735	717	717	0
Counterweight 6: 2 x 11,685 lbs [5.3t]**	23,594	8,139	8,057	2,507	2,445	2,445	0

Counterweight on the carrier:							
Counterweight 9: 5,291 lbs [2.4 t]** base plate	5,171	1,784	1,766	549	536	536	0
Counterweight 8: 7,496 lbs [3.4 t]**	7,497	2,586	2,560	797	777	777	0
Counterweight 7: 19,621 lbs [8.9 t]**	19,267	6,646	6,580	2,047	1,997	1,997	0
Counterweight 5: 22,046 lbs [10.0 t]**	21,962	7,581	7,505	2,330	2,273	2,273	0

** Metric

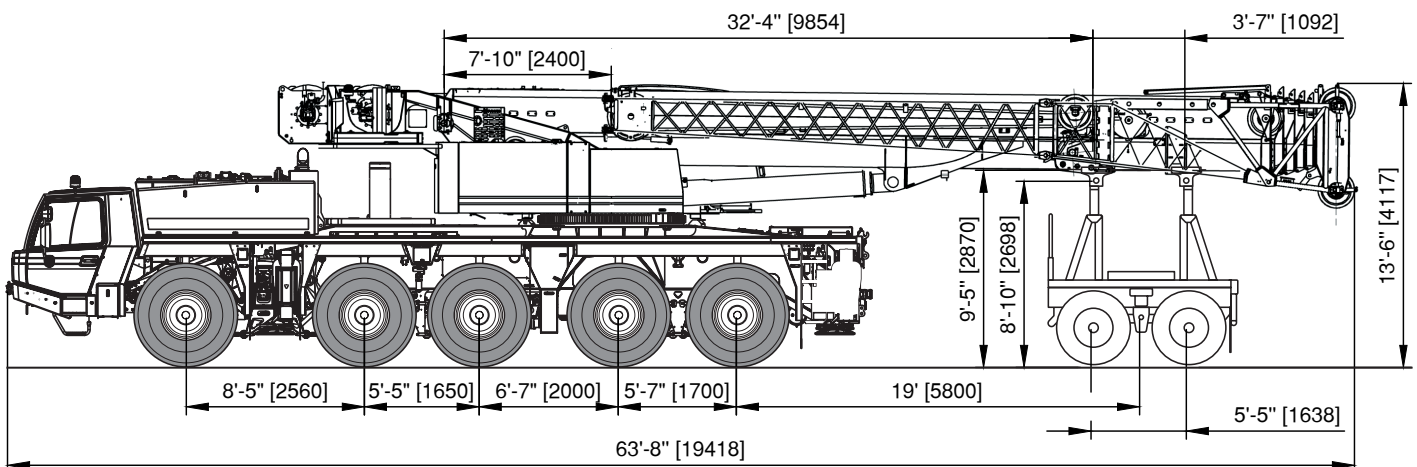

Counterweight versions / Variaciones de contrapeso

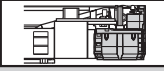
	Counterweight Contrapeso	1x	1x	1x	1x	1x	2x	1x	1x	1x
		①	②	③	④	⑤	⑥	⑦	⑧	⑨
	[lbs]	3,307	2,645	2,645	6,834	22,046	11,685	19,621	7,496	5,291

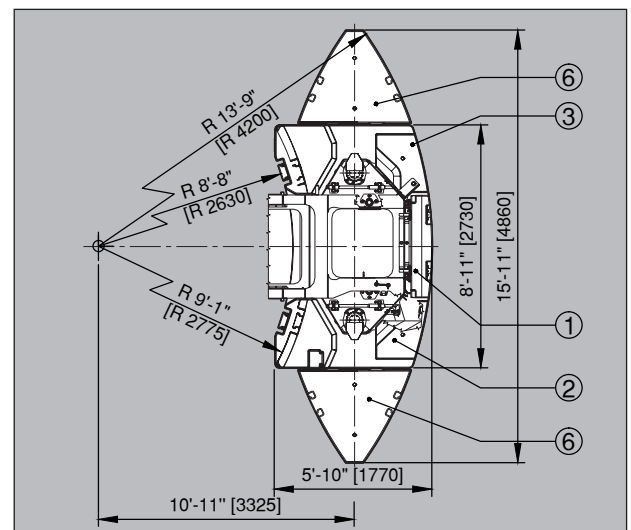
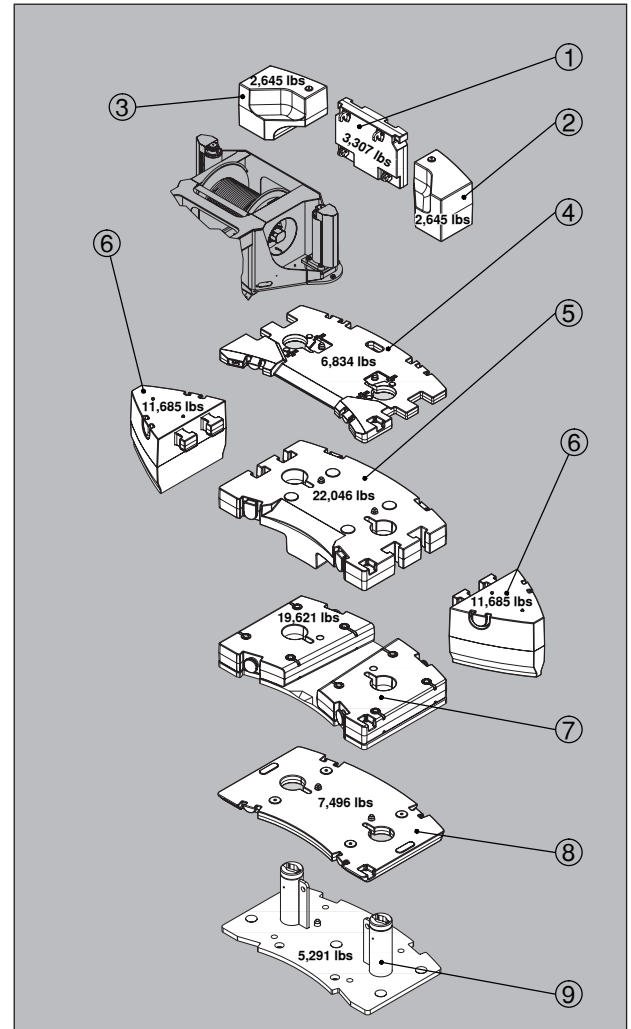
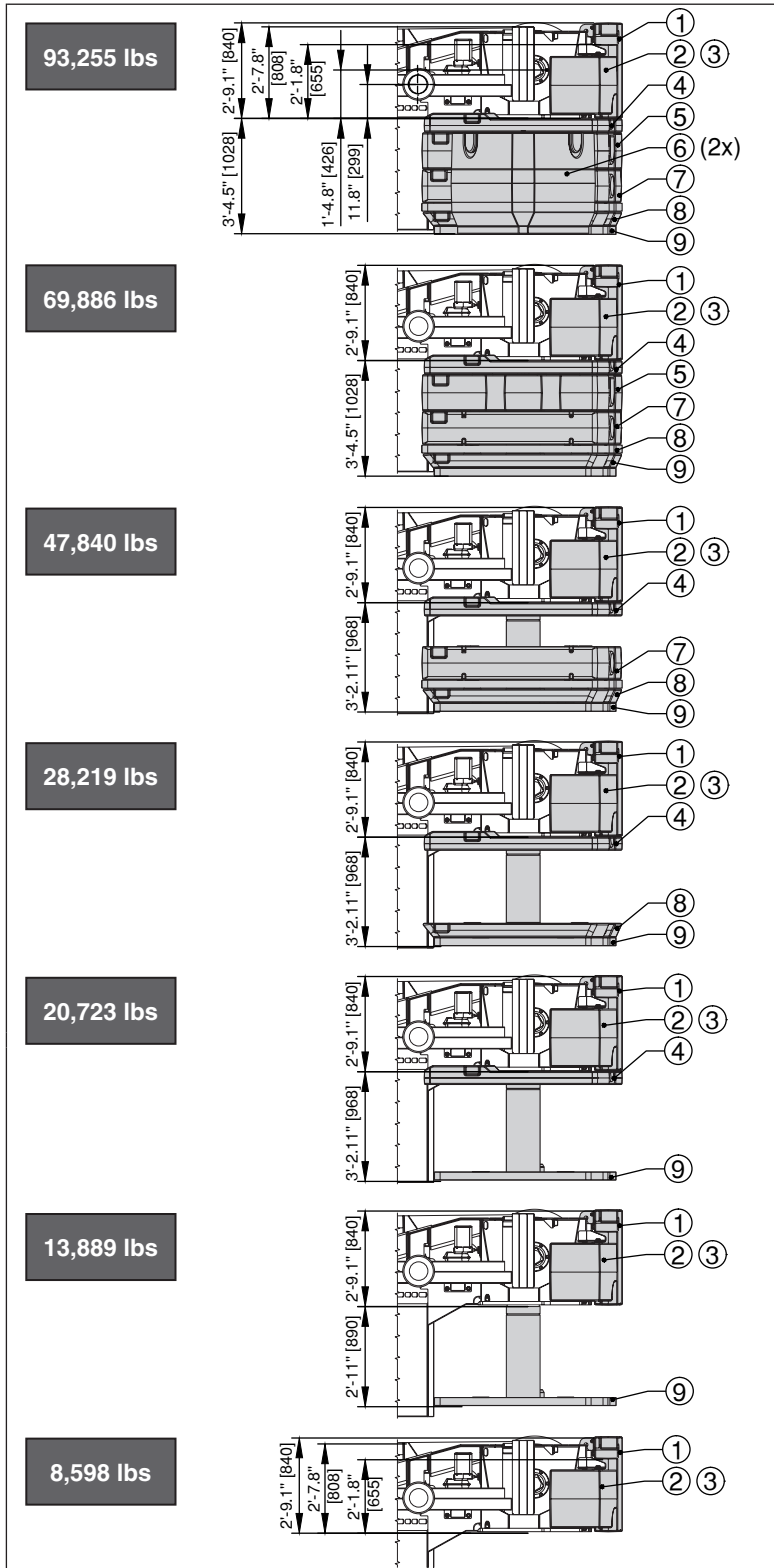



Frame Torsion-resistant, welded construction made from high strength, fine grained steel. Central lubricating system.

Outriggers 4 point, double telescopic hydraulic outriggers with controls on both sides of carrier and in superstructure cab. Outrigger base 24'-7" (7.5 m) {16'-5" (5.0 m) mid extension} x 26'-4" (8.03 m).

Carrier engine Mercedes-Benz 8 cylinder model OM 502 LA (Euromot III b/Tier 4i), water-cooled diesel engine. Rated at 551 HP (405 kW) at 1,800 rpm. Torque 1,918 ft-lbs (2,600 Nm / 265 kpm) at 1,300 rpm. Engine rating according to 80 / 1269 / EWG. Fuel tank 132 gal (500 l). DEF Tank 11 gal (40 l).

Transmission ZF-AS-Tronic 12 AS 2302 mechanical transmission with integrated interarder, electro-pneumatically operated dry-type clutch and automatic gear shifting with 12 forward gears and 2 reverse gears. Power / Economy modes.

Transfer Case Two stage.

Drive 10 x 6 (10 x 8 optional*)

Axles

1st axle: steered, not driven.

2nd axle: steered, driven.

3rd axle: steered, not driven.

4th axle: steered, driven, with longitudinal differential lock.

5th axle: steered, driven.

All driven axles with transverse differential locks.

Suspension Hydro-pneumatic with levelling adjustment.

Brake system Service disc brakes: dual circuit compressed air system with electrically wear control and air dryer. Parking brake: spring loaded type acting on 3rd, 4th and 5th axles. Auxiliary brakes: Intarder / Bremsomat function, engine exhaust brake and constant throttle engine brake system.

Tires (10) 445/95 R 25 (16.00 R 25), width 9' (2.75 m).
(10) 525/80 R 25 (20.50 R 25), width 9'-10" (3.00 m).

Steering system ZF-Servoocom, dual circuit hydraulic steering with emergency steering pump, mechanical hydraulically-assisted steering of front two axles and automatic steering of the 3rd and 4th axle up to a travel speed of 15.5 mph (25 km/h) and of the 5th axle up to 31.1 mph (50 km/h).

Carrier cab Two-man full width cab of composite (steel sheet metal and fibre-glass) structure, with safety glass, air-cushioned adjustable seats (driver seat with heater) and engine based water heater, radio/CD-player, complete controls and instrumentation for road travel. Cruise control with hill breaking feature functions.

Electrical system 24 volt DC system, 2 batteries, CAN-Bus system with CSS integrated self-diagnosis system, outrigger area lighting. Electrical system conforms with European standard regulations.

Optional Equipment (at extra charge)

Towing attachment, engine independent additional cab heater with engine pre-heat, air conditioning, ABS, 525 / 80 R 25 (20.50 R 25) tires, spare wheel and tire, special painting and lettering.

Further optional equipment available upon request.

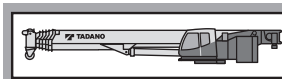

Frame Torsion-resistant, all-welded structure of high strength steel. Connected to carrier by single-row ball bearing slewing ring with external gearing for 360° continuous rotation. Central lubricating system.

Superstructure engine Mercedes-Benz 4 cylinder model OM 924 LA (Euromot III b/Tier 4i), water-cooled, diesel engine. Rated at 173 HP (127 kW) at 2,000 rpm. Torque 498 ft-lbs (675 Nm / 69 kpm) at 1,200 - 1,600 rpm. Engine rating according to 80 / 1269 / EWG. Fuel tank 58 gal (220 l). DEF Tank 2 gal (8 l).

Hydraulic system Three circuit diesel hydraulic system with 1 power controlled double axial piston pump (electrically adjustable) and 1 axial piston pump and 2 gear pumps, oil cooler.

Controls Electrical, 2 joy-stick levers for simultaneous operation of crane motions.

Telescopic boom 6 sections, made of high tensile, fine-grained steel, consisting of 1 base section and 5 telescoping sections extended by means of a single telescopic cylinder. All telescope sections extendable under partial load. 42.0 ft (12.8 m) to 196.8 ft (60.0 m) long. Boom head with 6 sheaves

Derricking system 1 double acting hydraulic cylinder with integral brake and holding valve, Slow-Stop-function.

Main winch Axial piston motor, winch drum with integrated planetary reduction and hydraulically controlled spring loaded, multiple disc brake and integrated free rotation (no sagging of load when hoisting). Hoist cable with 'Super-Stop' easy reeving system.

Slewing system Axial piston motor with three-stage planetary gear equipped with a foot actuated or automatic service brake and a parking brake. Open circuit with free slewing function. Speed infinitely variable 0 - 1.6 rpm.

Counterweight Total 93,255 lbs (42,3 t) divisible, assembled and disassembled by hydraulic cylinders controlled from superstructure cab.

Superstructure cab Spacious panoramic cab of composite structure with safety (tinted) glass windows, tiltable cockpit with hydraulically cushioned adjustable seat with heater, engine independent additional heater with engine pre-heat, air conditioning, radio/CD player. Complete controls and instrumentation for crane operation. Outrigger and engine controls from the superstructure.

Electrical system 24 volt DC system, 2 batteries.

Safety devices 'Lift Adjuster', load moment device (LMD), working area limiter, hoist limit switch, lower limit switch and drum turn indicator, Slow-Stop-function for slewing system and derricking system, safety valves against pipe and hose rupture, holding valves on hydraulic cylinders.

Optional Equipment (at extra charge)

Boom extensions 12.5 ft to 105.0 ft, offsets 0°, 20° and 40° or hydraulically 0°- 40°, LMD programme for 28,219 lbs (12,8 t) and 47,840 lbs (21,7 t) counterweight, 10 t swivel hook, selection of hook blocks 27.6 tons - 137.7 tons, auxiliary winch, engine independent additional heater with engine pre-heat, additional oil cooler, air conditioning, special painting and lettering, outrigger load display.

Further optional equipment available upon request.

Equipo



Chasis portante Construcción de acero de alta resistencia soldado, resistente a la torsión y a la flexión. Sistema de engrase central.

Estabilizadores Estabilizadores hidráulicos de 4 puntos. Posibilidad de manejo desde ambos lados del chasis portante y desde la cabina de la grúa. Extensión de los estabilizadores: 7,5 m (y 5,0 m) x 8,0 m.

Motor Mercedes Benz modelo OM 502 LA (Euromot III B / Tier 4i), 8 cilindros, diesel, refrigerado por agua. Nominal 405 kW (551 CV) a 1800 min⁻¹. Par 2600 Nm (265 kpm) a 1300 min⁻¹. Potencia del motor según 80 / 1269 / EWG. Depósito de combustible de 500 l. Depósito AdBlue 40 l.

Transmisión Transmisión mecánica tipo ZF-AS Tronic modelo 12 AS 2302 con intarder integrado, accionamiento electro-neumático embrague en seco y cambio automático, 12 marchas delanteras y 2 marchas traseras. Modo rendimiento máximo / económico.

Transmisión Caja de distribución (transfer) con 2 relaciones de velocidad.

Tracción 10 x 6 (10 x 8 como opción*)

Ejes

- 1º eje: de dirección, no accionado
- 2º eje: de dirección, accionado, con bloqueo diferencial transversal.
- 3º eje: de dirección, no accionado.
- 4º eje: de dirección, accionado, con bloqueo diferencial transversal y longitudinal.
- 5º eje: de dirección, accionado, con bloqueo diferencial transversal.

Suspensión Suspensión hidroneumática con regulación de nivel.

Sistemas de frenos Accionamiento neumático de doble circuito con indicador eléctrico de desgaste de freno y secador de aire. Freno de estacionamiento del tipo muelles cargados, liberados por aire, sobre los ejes 3º, 4º y 5º. Intarder / sistema automático de frenado y freno continuo: Freno de motor diesel en el escape.

Neumáticos 10 x 445 / 95 R 25 (16.00 R 25), (ancho 2.75 m).
10 x 525 / 80 R 25 (20.50 R 25), (ancho 3.00 m).

Dirección Hidráulica ZF Servocom de doble circuito con bomba auxiliar de dirección. Dirección mecánica del 1º y 2º eje y direccional del 3º y 4º eje hasta una velocidad de 25 km / h y del 5º eje hasta una velocidad de conducción de 50 km / h.

Cabina Cabina para dos personas, en construcción de acero y fibra de vidrio. Cristales de seguridad, asiento con suspensión neumática, asiento de conductor calefactado. Calefacción por agua caliente del motor, radio/CD player. Elementos de control y manejo para circular por carretera. Regulador de velocidad, sistema automático de frenado.

Sistema eléctrico Sistema de 24 V c.c. con dos baterías, conexiones eléctricas integradas en el sistema CAN-Bus, sistema integrado de diagnóstico -CSS. Faros de trabajo en los estabilizadores, 2 luces rotativas, alarma de marcha atrás. El sistema eléctrico cumple la normativa CEE.

Equipo adicional (con suplemento de precio)

Embrague de remolque, calefacción adicional con precalefacción del motor, climatización, ABS, neumáticos 525 / 80 R 25 (20.50 R 25), rueda de repuesto, pintura especial y rotulación.

Otros equipamientos sobre pedido.

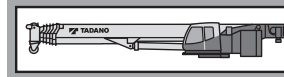

Superestructura Construida en aceros soldados, resistente a la torsión. Corona de giro con rodamiento de una fila de bolas con dientes externos para giro continuo a 360°. Sistema de engrase central.

Motor Mercedes Benz modelo OM 924 LA (Euromot III B / Tier 4i), 4 cilindros, diesel, refrigerado por agua. Las revoluciones aumentan de forma gradual accionando el acelerador. Nominal 127 kW (173 CV) a 2000 min⁻¹. Par 675 Nm (69 kpm) a 1200 - 1600 min⁻¹. Potencia del motor según 80 / 1269 / EWG. Depósito de combustible de 250 l. Depósito AdBlue 8 l.

Sistema hidráulico Sistema hidráulico de 3 circuitos, 1 bomba doble de pistones axiales de caudal variable (regulable eléctricamente) una bomba de pistones axiales y 2 bombas en tandem, enfriador de aceite.

Mandos 2 palancas de control de tipo joy-stick para movimientos simultáneos de la grúa (4 direcciones), asistidos eléctricamente.

Pluma telescópica 6 secciones, un tramo base y 5 telescópicos de acero de alta resistencia soldado, 1 cilindro hidráulico, los tramos se pueden telescopar hidráulicamente bajo carga. Longitud de 12,8 m a 60,0 m. Cabeza de pluma con 6 poleas.

Elevación de pluma Mediante un cilindro hidráulico de doble efecto con válvula de retención integrada, funciones 'Slow-Stop'.

Cabrestante principal Motor hidráulico de pistones axiales y caudal fijo. Tambor del cabrestante con reducción planetaria y frenos de disco múltiples accionado, con sistema libre de elevación. Cable de elevación con sistema fácil de guiado y 'Super-Stop'.

Sistema de giro Motor hidráulico de pistones axiales con reducción planetaria de tres etapas. Freno de giro controlado por pedal y freno de giro automático de bloqueo. Circuito abierto con mecanismo de giro libre con posibilidad de desconexión. Velocidad de giro gradual de 0 a 1,6 min⁻¹.

Contrapeso Peso total 42,3 t divisible, se acciona desde la cabina de la grúa.

Cabina de la grúa Cabina espaciosa y confortable, en construcción de acero y fibra de vidrio, con cristales tintados de seguridad. Asiento de operador regulable amortiguado hidráulicamente, inclinable junto con los instrumentos y mandos, asiento calefactado. Calefacción adicional con precalefacción del motor, climatización, radio/CD player. Elementos de control y mando para el manejo de la grúa. Accionamiento de los estabilizadores y motor desde la superestructura.











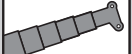
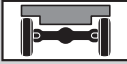
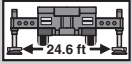
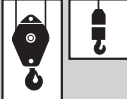



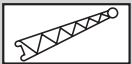
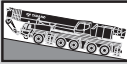

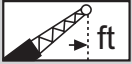

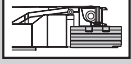
Sistema eléctrico Sistema de 24 V c.c. con dos baterías.

Medidas de seguridad 'Lift Adjuster', limitación del momento de carga (LMC), limitación del área de trabajo, interruptor de final de elevación, interruptor de 3 últimas vueltas en cabrestante, indicador de bajada o subida del cable del cabrestante, para las funciones 'Slow-Stop' de giro y abatimiento, válvulas de seguridad para rotura de tubos y latiguillos. Válvulas de retención en los cilindros hidráulicos.

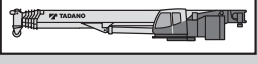
Equipo adicional (con suplemento de precio)

Plumín de 3,8 m / 10,2 m / 18,0 m / 25,0 m / 32,0 m regulable de 0°, 20° y 40° (o hidráulicamente 0° a 40°), prolongación, programación LMC en el sistema de limitación de cargas, para contrapesos de 12,8 t y 21,7 t, 10 t gancho de bola, gancho de 25 a 125 t, 2º cabrestante, enfriador adicional, pintura especial y rotulación, control carga (gatos de apoyo).

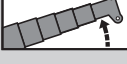
Otros equipamientos sobre pedido.

 445/95 R 25 (16.00 R 25)	Tires / Size Neumáticos / Tamaño de ruedas		Telescopic boom Pluma telescópica
	Axle load Carga por eje		Outriggers Estabilizadores
	Hook block / Swivel hook Gancho / Gancho de bola		Counterweight Contrapeso
	Carrier speeds Velocidades del chasis		Radius Radio
	Transmission / Gear Transmisión / Marchas		Boom extension Plumin
	Gradeability Superacion de pendientes		Boom extension hydraulically Plumin hidráulicamente
	Off road Todo terreno		Radius Radio
	On road En carretera		Counterweight versions Variaciones de contrapeso
	Superstructure speeds Velocidades de la superestructura		Carrier chasis
	Main winch Cabrestante principal		Superstructure superestructura
	Auxiliary winch 2° cabrestante		The data are for basic information only and the operator's manual must be consulted before operating this crane. All data and performances refer to the standard crane. The addition of optional and other equipment may affect the performance of the crane.
	Slewing system Sistema de giro	Los datos sirven solamente para su información. Hay que leer las instrucciones para el uso antes de la puesta en servicio de la máquina. Todos los datos mencionados en las presentes tablas rigen para los modelos standard. Cualquier modificación del equipo montado puede dar lugar a modificaciones de aquellos valores.	
	Derricking system Elevación de pluma		
	Boom telescoping Telescopaje de pluma		



TADANO AMERICA Corporation

4242 West Greens Road, Houston, TX 77066

Phone: 281-869-0030 Fax: 281-869-0040

www.tadanoamerica.com E-mail: tac.sales@tadano.com

Parts Hotline: 281-869-0033 Service Hotline: 281-869-5925